

6180 AeroDAQ

MODEL



Secure Graphic Recorder for AMS2750D

Specification Sheet

The 6180 AeroDAQ is designed to meet the specifications of the aerospace industry. Automated scheduling of TUS (Temperature Uniformity Survey), SAT (System Accuracy Test), and instrument calibration is handled by the AeroDAQ based on furnace class and instrument type as per the relevant tables of AMS2750D. A Service Page clearly displays the number of days until the next activity is due with messages to alert that the due date is approaching. Additionally, the AeroDAQ also monitors control thermocouple life for number of days used, and load thermocouples for both number of days used and number of uses. A pre-batch thermocouple life check will indicate the availability of the thermocouples for the next batch returning either OK or Will Fail with the reason (either days or uses will expire). Data is stored in a tamper-resistant binary format that can be used for secure, long term records of your process. The high accuracy, low drift input boards enable the AeroDAQ to meet the requirements of AMS2750D for Class 1 Furnace.

- Colour touchscreen display
- USB 'plug & play'
- 6 universal Inputs
- 32MB non-volatile flash memory
- 125ms parallel sampling
- Compact Flash
- Modbus RTU
- Ethernet TCP/IP
- Web server
- EtherNet/IP server
- Multi-language support (including Chinese, Korean and Cyrillic)

Available features*	 6180 AeroDAQ
Display	12.1" XGA
Channels	6
Relays	3
Groups	6 standard
Auditor features	Audit trail
Virtual channels**	36
Timers	Fitted as standard
Alarms	4 per channel
Batch	Standard
Bridge- remote viewing software	Full as standard
Screen builder	Standard
Modbus Master	Standard
Security	Unlimited unique user names with configurable access permissions and passwords
Configuration software	Standard
Review/Quickchart Lite software	Standard
Standard views	Vertical and horizontal trending, Vertical and horizontal bargraphs, Circular trend and numeric values

* Standard AeroDAQ features shown. Additional options available as per ordering code

** Virtual channels can be configured as maths, totalisers, counters or comms

Data logging and archiving

The AeroDAQ has internal Flash memory for secure data storage. They are also able to accept various removable media types (Compact Flash or USB memory stick). Data stored within the internal memory can be archived to the removable media on demand or at preset intervals. The AeroDAQ will give indication of how long its internal memory and that of the removable media installed will last according to the configuration of the recorder.

The AeroDAQ has Ethernet capability. It can be configured to archive to the removable media and/or over Ethernet. Archiving files over Ethernet effectively gives a secure, infinite archiving capacity.

Approximate duration for continuous recording of one group of six channels, high compression:

Archive Media	Sample Rate						
	0.125s	0.5s	1s	5s	10s	30s	60s
32Mb Internal Flash (approx. 4 million samples)	2.83 days	11.3 days	22.6 days	113 days	226 days	1.86 yrs	3.7 yrs
64Mb CF Card or USB memory stick (approx. 8 million samples)	5.66 days	22.6 days	45.3 days	226 days	1.2 yrs	3.7 yrs	7.4 yrs
256Mb CF Card or USB memory stick (approx. 32 million samples)	22.6 days	90.6 days	181 days	2.4 yrs	4.9 yrs	14.8 yrs	20 yrs
1Gb CF Card or USB memory stick (approx. 125 million samples)	88 days	354 days	1.9 yrs	9.6 yrs	19 yrs	58 yrs	116 yrs
8Gb CF Card or USB memory stick (approx. 1000 million samples)	1.9 yrs	7.8 yrs	15.2 yrs	76.8 yrs	152 yrs	464 yrs	928 yrs
16Gb CF Card or USB memory stick (approx. 2000 million samples)	3.8 yrs	15.6 yrs	30.4 yrs	153.6 yrs	304 yrs	928 yrs	1856 yrs
Ethernet (FTP Server)	Infinite						

Time synchronisation (SNTP)

The AeroDAQ supports Simple Network Time Protocol which, when enabled, updates the instrument time every 15 minutes from the configured SNTP server. The unit can also act as a Unicast SNTP server on the network, allowing client instruments to synchronise with the AeroDAQ to a resolution of one millisecond.

Batch recording

Up to ten user-defined fields can be used to enter batch specific data.

Field descriptor	Operator entered batch information
– up to 20 characters	– up to 60 characters

The user can choose to log any number of the given fields on start and/or stop of a batch. The information will appear on the chart as a message and cannot be separated from the process data to which it relates.

Audit trail

Standard on the AeroDAQ is a time stamped audit trail. This allows all actions taken on the recorder including all user logins, batch start and stop, TUS, SAT and calibration reset, and any configuration changes to be shown on the “chart” as well as becoming a permanent part of the history file. The audit trail information can be seen in historic views of the data.

Modbus master

Allows users to view data from multiple instruments connected either by a local Network connection using Modbus TCP, or a Serial connection using Modbus RTU.

ASCII printer output (reports)

Fitted as standard the ASCII text printer option provides the AeroDAQ with the ability to generate up to 10 simple reports that can be directed to a Serial ASCII text printer. Reports, triggered by an event/job can be configured to contain parameters such as time and date, batch names, process values and user defined messages.

Dynamic Host Configuration Protocol (DHCP)

Dynamic Host Configuration Protocol, the successor to BootP, allows an AeroDAQ host to obtain Network parameters, such as IP address, Subnet Mask, default gateway and DNS server address dynamically. The implementation of DHCP on the AeroDAQ significantly reduces the overhead for maintaining a network of instrumentation.

SPECIFICATION

Recorder

Environmental performance

Temperature limits Operation: 0 to +50°C
Storage: –20 to 60°C
Humidity limits Operation: 5% to 80% RH
Storage: 5% to 90% RH
Protection Bezel and display: IP66
Sleeve: IP20

Shock: BS EN61010
Vibration (10 to 150Hz): BSEN60873, Section 9,18
Altitude: <2000 metres

Approvals

Electromagnetic compatibility CE, cUL (EMC)

UL file number: e57766
Emissions and immunity: BS EN61326

Electrical safety

(BS EN61010): Installation cat. II; Pollution degree 2

INSTALLATION CATEGORY II

The rate impulse voltage for equipment on nominal 230V mains is 2500V.

POLLUTION DEGREE 2

Normally, only non-conductive pollution occurs. Occasionally, however, a temporary conductivity caused by condensation shall be expected.

Physical

Panel mounting: DIN43700
Panel mounting angle: ±45°
Dimensions Bezel size: 292 x 292mm
Panel cutout: 281 x 281mm (both –0/+1mm)
Depth behind bezel rear face: 261mm
Weight: 7kg max.

Operator interface

Type: Colour TFT LCD with cold cathode backlight, fitted with resistive, analogue, Touch-Panel
Size and resolution: XGA (1024 x 768 pixels) 12.1”

Power requirements

Supply voltage Standard: 85 to 265V ac; 47 to 63Hz or 110 to 370V dc
Low voltage option*: 20 to 42V RMS; 45 to 400Hz or 20 to 54V dc

Power (Max): 50W
Fuse type: None
Interrupt protection Standard: Holdup >200msec, at 240V ac, with full load

Back-up battery

Type: Poly-carbonmonofluoride/lithium (BR2330) Part No. PA261095
Support time (RTC): 1 year min. with recorder unpowered
Replacement period: 3 years
Stored data: Time; date; values for totalisers, counters and timers; batch data; Evalue, Rolling average, Stopwatch etc.

Ethernet communications

Type: 10/100baseT Ethernet. (IEEE802.3)
Protocols: TCP/IP, FTP, DHCP, BOOTP, SNTP, MODBUS, SMTP, ICMP, EtherNet/IP server
Cable Type: CAT5
Maximum length: 100 metres
Termination: RJ45

Serial communications option

No of ports: 2
Protocol: ASCII (typical applications: Input of ASCII string inputs from Barcode readers, Credit card readers etc.)
ASCII printer support
Modbus RTU Master and Slave
Installation category II;
Pollution degree 2
Isolation (dc to 65Hz BS EN61010):
Terminals to ground: 50V RMS or dc (basic insulation)
Transmission standard: EIA232 or EIA485 (software selectable)

* Please consult Eurotherm for this option

Input Board

General

Input types:	dc Volts, dc millivolts, dc milliamps (with shunt), Thermocouple, 2/3-wire RTD
Input type mix:	Contact closure (not Channels 1, 7, 13, 19, 25, 31, 37, 43) >60 ms
Maximum number of inputs:	Freely configurable.
A/D conversion method:	6 per board
Input ranges:	>16 bits, 2nd order delta sigma
Termination:	See Table 1 and Table 2 below
Noise rejection (48 to 62Hz):	Edge connector / terminal block
Max common mode voltage:	Common mode: >140dB (channel to channel and channel to ground).
Max series mode voltage:	Series mode: >60dB
Isolation Channel to channel:	250V continuous
Channel to common electronics:	45mV at lowest range;
Channel to ground:	23.74 Volts peak at highest range.
Dielectric strength (BS EN61010)	300V RMS or dc (double insulation)
Channel to channel:	1500V ac
Channel to ground:	1500V ac
Insulation resistance:	>10MΩ at 500V dc
Input impedance:	38mV, 150mV, 1V ranges: >10MΩ; 20V range: 65.3kΩ
Over voltage protection:	50V peak (150V with attenuator)
Open circuit detection:	± 57nA max.
Recognition time:	500msec
Minimum break resistance:	10MΩ

Update/archive rates

Input/Relay-output sample rate:	8Hz
Trend update:	8Hz maximum
Archive sample-value:	Latest value at archive time
Display value:	Latest value at display update time (8Hz)

DC Input ranges

Shunt:	Externally mounted resistor modules
Additional error due to shunt:	0.1% of input
Additional error due to attenuator:	0.2% of input
Performance:	See Table 1
Long term drift:	Meets the requirements of AMS2750D for Class 1 Furnace
	Requires an Input Adjust to be performed to meet the requirements of AMS2750D

Low Range	High Range	Resolution	Typical error (instrument at 20°C) Range	Maximum error (instrument at 20°C) Range	Worst case temp Performance Input per °C
-38mV	38mV	1.4μV	0.013% I/P + 0.031%	0.030% I/P + 0.052%	25ppm
-150mV	150mV	5.5μV	0.013% I/P + 0.028%	0.029% I/P + 0.039%	25ppm
-1V	1V	37μV	0.013% I/P + 0.024%	0.029% I/P + 0.029%	25ppm
-20V	20V	720μV	0.075% I/P + 0.027%	0.393% I/P + 0.033%	388ppm

Table 1 Voltage ranges - accuracy and resolution

Low Range	High Range	Resolution	Typical error (instrument at 20°C) Range	Maximum error (instrument at 20°C) Range	Worst case temp Performance Input per °C
0Ω	150Ω	5mΩ	0.027% I/P + 0.034%	0.037% I/P + 0.077%	30ppm
0Ω	600Ω	22mΩ	0.027% I/P + 0.035%	0.037% I/P + 0.057%	30ppm
0Ω	5KΩ	148mΩ	0.030% I/P + 0.034%	0.040% I/P + 0.041%	30ppm

Table 2 Resistance ranges - accuracy and resolution

Thermocouple data

Temperature scale:	ITS 90
Bias current:	0.05nA
Cold junction types:	Off, internal, external, remote
CJ error:	1°C max with inst. at 25°C
CJ rejection ratio:	50:1 minimum
Upscale/downscale drive:	High, low or none selectable for each thermocouple channel
Types and ranges:	Additional error: 0.01°C (typ.) if high or low selected
	See Table 3

Resistance inputs

Ranges (including lead resistance):	0 to 150Ω, 0 to 600Ω, 0 to 6kΩ
Influence of lead resistance:	Error: Negligible
	Mismatch: 1Ω/Ω
Temperature scale:	ITS90
Accuracy and resolution:	See Table 2
RTD types and ranges:	See Table 4

T/C Type	Overall range (°C)	Standard	Max linearisation error
B	0 to +1820	IEC 584.1	0 to 400°C = 1.7°C 400 to 1820°C = 0.03°C
C	0 to +2300	Hoskins	0.12°C
D	0 to +2495	Hoskins	0.08°C
E	-270 to +1000	IEC 584.1	0.03°C
G2	0 to +2315	Hoskins	0.07°C
J	-210 to +1200	IEC 584.1	0.02°C
K	-270 to +1372	IEC 584.1	0.04°C
L	-200 to +900	DIN43710:1985 (To IPTS68)	0.02°C
N	-270 to +1300	IEC 584.1	0.04°C
R	-50 to +1768	IEC 584.1	0.04°C
S	-50 to +1768	IEC 584.1	0.04°C
T	-270 to +400	IEC 584.1	0.02°C
U	-200 to +600	DIN43710:1985	0.08°C
NiMo/NiCo	-50 to +1410	ASTM E1751-95	0.06°C
Ni/NiMo	0 to +1406	Ipsen	0.14°C
Platinel	0 to +1370	Engelhard	0.02°C
Pt20%Rh/ Pt40%Rh	0 to +1888	ASTM E1751-95	0.07°C

Table 3 Thermocouple types and ranges

RTD Type	Overall range (°C)	Standard	Max linearisation error
Cu10	-20 to +400	General Electric Co.	0.02 °C
Cu53	-70 to ± 200	RC21-4-1966	<0.01°C
JPT100	-220 to +630	JIS C1604:1989	0.01 °C
Ni100	-60 to +250	DIN43760:1987	0.01 °C
Ni120	-50 to +170	DIN43760:1987	0.01 °C
Pt100	-200 to +850	IEC 751	0.01 °C
Pt100A	-200 to +600	Eurotherm Recorders SA	0.09 °C
Pt1000	-200 to +850	IEC 751	0.01 °C

Table 4 RTD types and ranges

Relay Output Board

General

Maximum number of relay boards	9 (max no of relay outputs = 36)
Number of relays per board	3 per C/O 4 per N/C 4 per N/O
Estimated mechanical life	30,000,000 operations
Update rate	See 'Update rates' in 'Recorder Specification' above

AC load ratings

Derating	The figures give below are for restive loads. For reactive or inductive loads, de-rate in accordance with Graph 1, in which
	F1 = Actually measured results on representative samples
	F2 = Typical values according to experience
	Contact life = Resistive contact life x reduction factor
Maximum switching power	500VA
Maximum contact voltage	250V providing this does not cause the maximum switching power (above) to be exceeded
Maximum contact current	2 Amps providing this does not cause the maximum switching power (above) to be exceeded

DC load ratings

Maximum switching power	See Graph 2 for operating volt/amp envelope
Maximum contact voltage/Current	See Graph 2 for examples

Safety isolation

Isolation (dc to 65Hz; BS EN61010)	Installation category II; Pollution degree 2
Relay to Relay:	300V RMS or dc (double insulation)
Relay to ground:	300V RMS or dc (basic insulation)

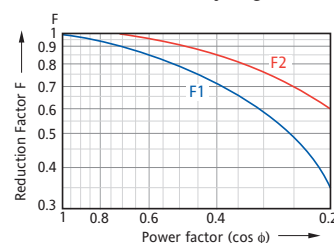

Graph 1 Derating curves for ac loads

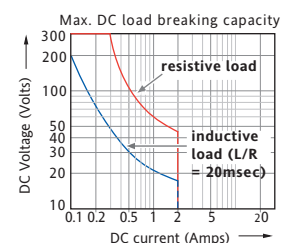

Graph 2 DC load switching curves

Mechanical installation

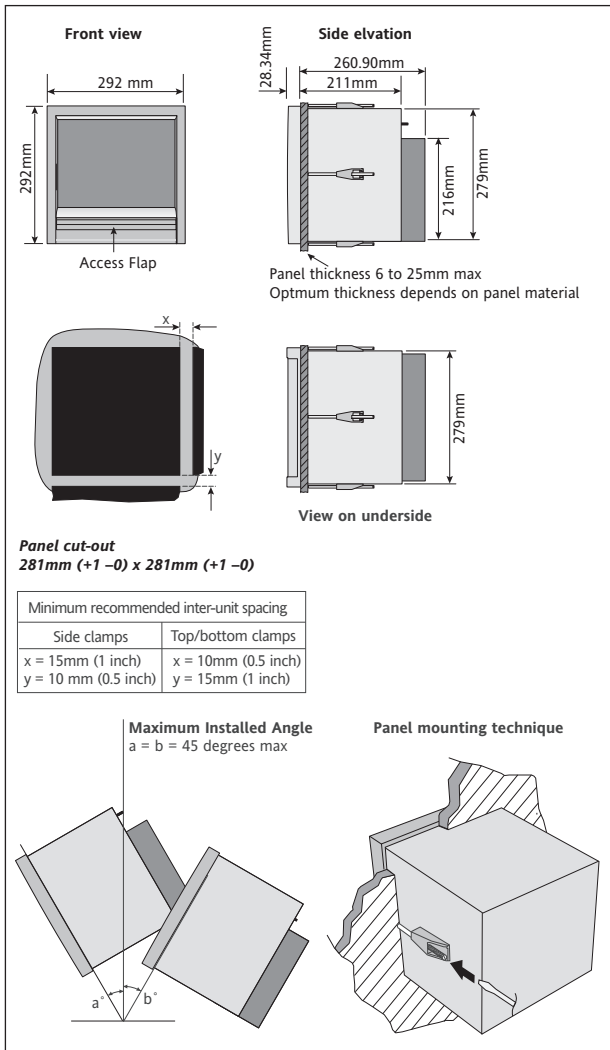

Rear terminal connections

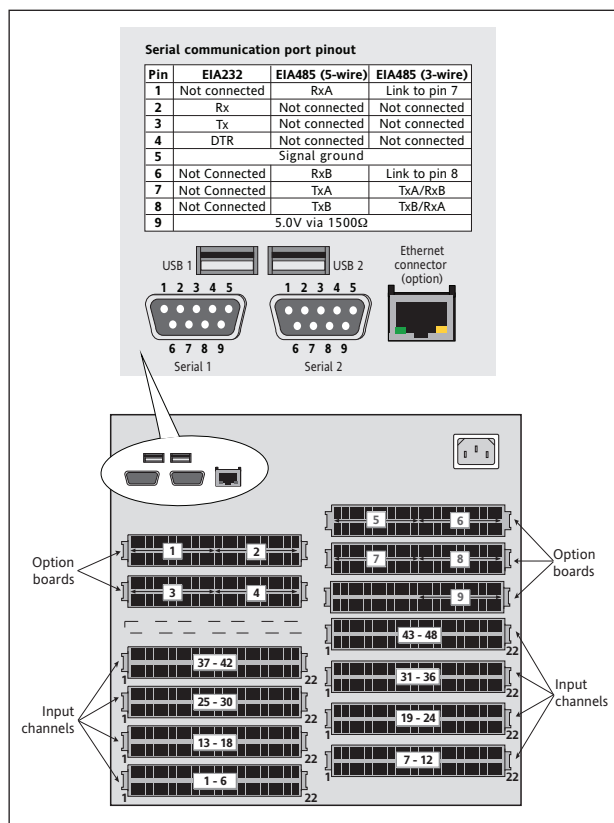

Input board wiring

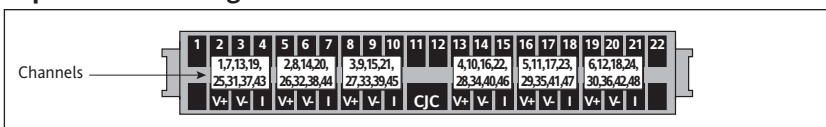

Relay board wiring

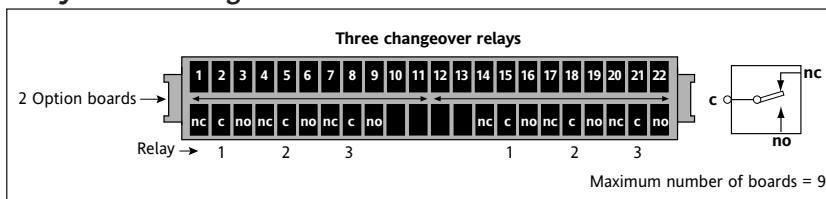

Input board signal wiring

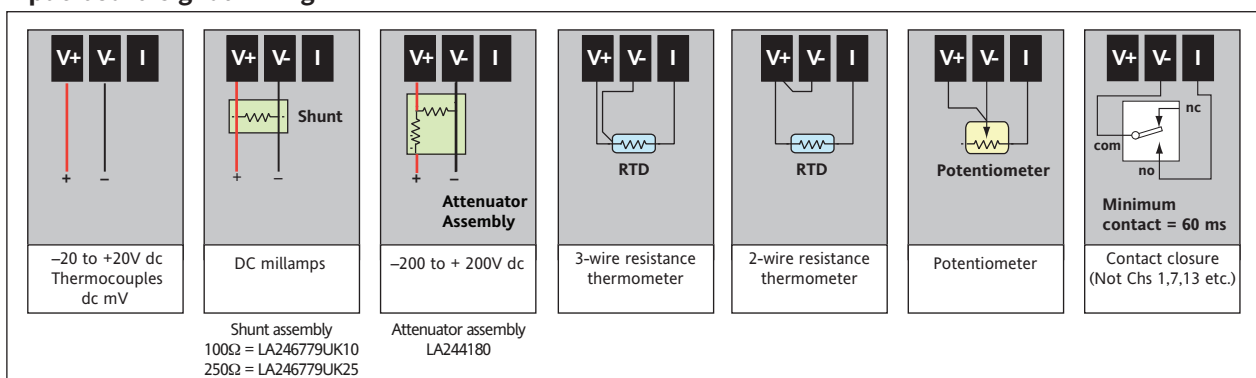

ORDERING CODE

6180A	1	2	3	4	5	6	7	8	9	10	11	12	13	
	14	15	16	17	18	19	20	21	22	23	24	25	26	27
	28	29	30	31	32	33	34							

Basic Product

6180A 180mm TFT XGA Display

1 Number of Channels

U00	0 Input channels
U06	6 Input channels
U12	12 Input channels
U18	18 Input channels
U24	24 Input channels
U30	30 Input channels
U36	36 Input channels
U42	42 Input channels
U48	48 Input channels

2 Industrial Variant

AERODAQ Industrial variant

3 Case Options

PANEL	Panel mounting
CH	Carry handle (Bexel Colour Silver)

4 Lock

NOLCK	Media lock not fitted
LOCK	Electronic lock fitted

5 Bezel Colour

SLV	Silver including portable options
GRN	Eurotherm Green
BLK	Black

6 Power Supply

VH	90-264V ac (110-370V dc) 47-63Hz
VL	20-42V ac (20-54V dc)*

7

XXXXX Not fitted

8 Non Standard

XXXXXX Non standard option

9 Internal Memory

032M	32MB for history - approx. 4 million samples
096M	96MB for history - approx. 12 million samples

10 Removable Media

CF	Compact Flash and Front USB port
SD	Secure Digital and Front USB port

11 Memory Card

NOMC	Not fitted
128M	128MB Card (CF or SD, dependant on removable media type)
256M	256MB Card (CF or SD, dependant on removable media type)
512M	512MB Card (CF or SD, dependant on removable media type)
001G	1GB Card (CF or SD, dependant on removable media type)

12 USB Memory Stick Size

NOMS	Not fitted
064MMS	64M byte
256MMS	256M byte
512MMS	512M byte
001GMS	1G byte

13 Rear USB

0RUSB	No rear USB ports
2RUSB	2 USB ports at rear

14 Serial Communications Ports

0SRL	Not fitted
2SRL	2EIA 232/422/485

15 EtherNet Communications Protocol

NONE	Not fitted
ESERV	EtherNet/IP server

16 Calibration Certificates

NOCAL	Not required
CAL	Calibration certificate

17 Changeover Relays

00	Not fitted
03	3 (1 option brd)
06	6 (2 option brds)
09	9 (3 option brds)
12	12 (4 option brds)
15	15 (5 option brds)
18	18 (6 option brds)
21	21 (7 option brds)
24	24 (8 option brds)
27	27 (9 option brds)

18 Normally Closed Relays

00	Not fitted
04	4 (1 option brd)
08	8 (2 option brds)
12	12 (3 option brds)
16	16 (4 option brds)
20	20 (5 option brds)
24	24 (6 option brds)
28	28 (7 option brds)
32	32 (8 option brds)
36	36 (9 option brds)

19 Normally Open Relays

00	Not fitted
04	4 ((1 option brd)
08	8 (2 option brds)
12	12 (3 option brds)
16	16 (4 option brds)
20	20 (5 option brds)
24	24 (6 option brds)
28	28 (7 option brds)
32	32 (8 option brds)
36	36 (9 option brds)

20 Event Inputs

00	Not fitted
06	06 (1 brd)
12	12 (2 brds)
18	18 (3 brds)
24	24 (4 brds)

21 Analogue Outputs

00	None
02	2 (1 option brd)
04	4 (2 option brds)
06	6 (3 option brds)
08	8 (4 option brds)

22 Quantity of Shunts

-- Enter qty required

23 Shunt Value

NOS	Not required
100	100 ohm shunts
250	250 ohm shunts

24 Qty of 100:1 Attenuators

-- Enter qty required

25 Warranty

XXXXX	Standard warranty
WL005	Extended warranty

26 Bridge

BLITE	Lite (supplied as standard)
BFULL	Full

27 Review and Quickchart

RLITE	Lite (supplied as standard)
RFULL	Full

28 Auditor

NOADT	Not required
ALITE	Audit Trail
AFULL	Auditor Full

29 Security Manager

NOSM	Not required
SECMAN	Security Manager

30 Groups

06GROUP	6 (supplied as standard)
12GROUP	12

31 Maths, Totalisers and Counters

MTC00	Not required
MTC36	36 Virtual Channels
MTC96	96 Virtual Channels
MTC128	128 Virtual Channels

32 Batch

NOBTCH	Not required
BATCH	Batch

33 Screen Builder

NOSB	Not required
ADSB	Advanced Screen Builder

34 Master Communications

NOMSTR	Not required
MSTR16	16 Slaves
MSTR32	32 Slaves

* Please consult Eurotherm for this option

Standard AeroDAQ Ordering code

6180A/U06/AERODAQ/NOLCK/SLV/VH/XXXXX/XXXXX/032M/CF/NOMC/NOMS/0RUSB/0SRL/NONE/NOCAL/00/00/00/00/00/NOS/00/XXXXX/BLITE/RLITE/ALITE/NGSM/06GROUP/MTC36/BATCH/ADSB/NOMSTR

0	Model 6180A 180mm TFT XGA Display	6180A
1	Number of channels 6 Input Channels	U06
2	Industry variant	AERODAQ
3	Case Options Panel mounting	PANEL
4	Lock Media lock not fitted	NOLCK
5	Bezel colour Silver including portable options	SLV
6	Power supply 90- 264 Vac (110-370V dc) 47 –63 Hz	VH
7	Not used	XXXXX
8	Non standard Non Standard Option	XXXXXX
9	Internal memory 32M Byte for history – approx 4 million samples	032M
10	Removable media Compact Flash and Front USB port	CF
11	Memory card size Not fitted	NOMC
12	USB Memory stick size Not fitted	NOMS
13	Rear USB No rear USB ports	0RUSB
14	Serial communication ports Not fitted	0SRL
15	EtherNet Communications Protocol	NONE
16	Calibration certificates Not required	NOCAL
17	Changeover relays Not fitted	00

18	Normally closed relays Not fitted	00
19	Normally open relays Not fitted	00
20	Event inputs Not fitted	00
21	Analogue outputs None	00
22	Quantity of shunts Enter quantity required	_ _
23	Shunt value Not required	NOS
24	Quantity of attenuators (100:1) Enter quantity required	_ _
25	Warranty Standard warranty	XXXXX
26	Bridge Bridge Lite (Supplied as standard)	BLITE
27	Review and quickchart Lite (supplied as standard)	RLITE
28	Auditor Audit Trail	ALITE
29	Security manager Not required	NOSM
30	Groups 6 Groups (supplied as standard)	06GROUP
31	Maths, totalisers and counters 36 Virtual Channels	MTC36
32	Batch Batch	BATCH
33	Screen builder Advanced screen builder	ADSB
34	Master communications Not fitted	NOMSTR

Eurotherm: International sales and service

Understanding and providing local support is a key part of Eurotherm business. Complementing worldwide Eurotherm offices are a whole range of partners and a comprehensive technical support team, to ensure you get a service you will want to go back to.

AUSTRALIA Sydney
Eurotherm Pty. Ltd.
T (+61 2) 9838 0099
F (+61 2) 9838 9288
E info.au@eurotherm.com

AUSTRIA Vienna
Eurotherm GmbH
T (+43 1) 7987601
F (+43 1) 7987605
E info.at@eurotherm.com

BELGIUM & LUXEMBOURG Moha
Eurotherm S.A./N.V.
T (+32) 85 274080
F (+32) 85 274081
E info.be@eurotherm.com

BRAZIL Campinas-SP
Eurotherm Ltda.
T (+5519) 3707 5333
F (+5519) 3707 5345
E info.br@eurotherm.com

CHINA
Eurotherm China
T (+86 21) 61451188
F (+86 21) 61452602
E info.cn@eurotherm.com

Beijing Office
T (+86 10) 63108914
F (+86 10) 63107291
E info.cn@eurotherm.com
Guangzhou Office
T (+86 20) 38106506
F (+86 20) 38106511
E info.cn@eurotherm.com

DENMARK Copenhagen
Eurotherm Danmark AS
T (+45 70) 234670
F (+45 70) 234660
E info.dk@eurotherm.com

FINLAND Abo
Eurotherm Finland
T (+358) 22506030
F (+358) 22503201
E info.fi@eurotherm.com

FRANCE Lyon
Eurotherm Automation SA
T (+33 478) 664500
F (+33 478) 352490
E info.fr@eurotherm.com

GERMANY Limburg
Eurotherm Deutschland GmbH
T (+49 6431) 2980
F (+49 6431) 298119
E info.de@eurotherm.com

HONG KONG
Eurotherm Hongkong
T (+85 2) 28733826
F (+85 2) 28700148
E info.hk@eurotherm.com

INDIA Chennai
Eurotherm India Limited
T (+91 44) 24961129
F (+91 44) 24961831
E info.in@eurotherm.com

IRELAND Dublin
Eurotherm Ireland Limited
T (+353 1) 4691800
F (+353 1) 4691300
E info.ie@eurotherm.com

ITALY Como
Eurotherm S.r.l.
T (+39 031) 975111
F (+39 031) 977512
E info.it@eurotherm.com

KOREA Seoul
Eurotherm Korea Limited
T (+82 31) 2738507
F (+82 31) 2738508
E info.kr@eurotherm.com

NETHERLANDS Alphen a/d Rijn
Eurotherm B.V.
T (+31 172) 411752
F (+31 172) 417260
E info.nl@eurotherm.com

NORWAY Oslo
Eurotherm A/S
T (+47 67) 592170
F (+47 67) 118301
E info.no@eurotherm.com

POLAND Katowice
Invensys Eurotherm Sp z o.o.
T (+48 32) 2185100
F (+48 32) 2185108
E info.pl@eurotherm.com

SPAIN Madrid
Eurotherm España SA
T (+34 91) 6616001
F (+34 91) 6619093
E info.es@eurotherm.com

SWEDEN Malmo
Eurotherm AB
T (+46 40) 384500
F (+46 40) 384545
E info.se@eurotherm.com

SWITZERLAND Wollerau
Eurotherm Produkte (Schweiz) AG
T (+41 44) 7871040
F (+41 44) 7871044
E info.ch@eurotherm.com

UNITED KINGDOM Worthing
Eurotherm Limited
T (+44 1903) 268500
F (+44 1903) 265982
E info.uk@eurotherm.com
www.eurotherm.co.uk

U.S.A. Leesburg VA
Eurotherm Inc.
T (+1 703) 443 0000
F (+1 703) 669 1300
E info.us@eurotherm.com
www.eurotherm.com

ED57

© Copyright Eurotherm Limited 2009

Invensys, Eurotherm, the Eurotherm logo, Chessell, EurothermSuite, Mini8, Eyon, Eyris, EPower and Wonderware are trademarks of Invensys plc, its subsidiaries and affiliates. All other brands may be trademarks of their respective owners.

All rights are strictly reserved. No part of this document may be reproduced, modified, or transmitted in any form by any means, nor may it be stored in a retrieval system other than for the purpose to act as an aid in operating the equipment to which the document relates, without the prior written permission of Eurotherm limited.

Eurotherm Limited pursues a policy of continuous development and product improvement. The specifications in this document may therefore be changed without notice. The information in this document is given in good faith, but is intended for guidance only.

Eurotherm Limited will accept no responsibility for any losses arising from errors in this document.

