

5000 Series

100 and 180 mm video-graphics recorders
Data acquisition and logging units

Serial Communications
and
Remote Viewer

User Guide

GRAPHICS RECORDER / DATA ACQUISITION UNIT

COMMUNICATIONS MANUAL

LIST OF SECTIONS

Section	Page
1 REMOTE VIEWER.....	7
2 MODBUS TCP SLAVE	15
3 MODBUS TCP MASTER	67
4 SERIAL COMMS	90
INDEX.....	95

Effectivity

This manual refers to a number of different recorders and data acquisition units, not all of which support all the communications options described herein, or may support the options but not be fitted with them. If an option is not supported or not fitted, it does not appear in the configuration menu.

For recorders which are being operated under Remote Viewer software, any mention, in this manual, of 'Push', 'Touch' or 'Operate' should be read as 'Click on'.

This User Guide, supplied with the unit specifies the Software Version to which this (communications) manual relates.

© 2003 Eurotherm Limited

All rights are strictly reserved. No part of this document may be reproduced, modified, or transmitted in any form by any means, nor may it be stored in a retrieval system other than for the purpose to act as an aid in operating the equipment to which the document relates, without the prior written permission of Eurotherm limited.

Eurotherm Limited pursues a policy of continuous development and product improvement. The specifications in this document may therefore be changed without notice. The information in this document is given in good faith, but is intended for guidance only. Eurotherm Limited will accept no responsibility for any losses arising from errors in this document.

**GRAPHICS RECORDER /
DATA ACQUISITION UNIT
COMMUNICATIONS MANUAL**

LIST OF CONTENTS

Section	Page
1 REMOTE VIEWER	7
1.1 INTRODUCTION	7
1.1.1 Minimum PC requirements	8
SUPPORTED PDA CONFIGURATION	8
1.2 CONNECTION DETAILS	9
1.2.1 Direct PC connection	9
1.2.2 PC To remote recorder	9
1.2.3 Networked systems	9
1.3 SOFTWARE INSTALLATION	10
1.4 RECORDER CONFIGURATION	10
1.4.1 Network	10
1.4.2 Options	10
1.4.3 Access	11
1.5 RUNNING THE PROGRAM	12
1.6 OPERATION	13
1.6.1 Display Modes	13
1.6.2 Alarm acknowledgement	13
1.6.3 Status line	13
1.6.4 Error messages	14
NETWORK CONNECTION HAS TIMED OUT	14
UNABLE TO CONNECT TO HOST	14
UNABLE TO RESOLVE HOSTNAME	14
FAILED TO AUTHENTICATE THE USER NAME	14
MAXIMUM REMOTE VIEWERS ALREADY CONNECTED TO	14
THERE APPEARS TO BE NO FREE DISK SPACE ON	14
YOU ARE ALREADY RUNNING A FULL REMOTE	14
YOU ARE AUTHENTICATING FULL REMOTE	14

Cont...

LIST OF CONTENTS (CONT.)

Section	Page
2 MODBUS TCP SLAVE COMMS	15
2.1 INSTALLATION	15
2.2 INTRODUCTION	15
2.2.1 Function Codes	15
DIAGNOSTIC CODES	15
EXCEPTION CODES	16
2.2.2 Data types	16
DATA ENCODING	16
2.2.3 Invalid multiple register writes	16
2.2.4 Security	16
TO SEND A LOGIN REQUEST	19
2.2.5 Text messages	21
LONG MESSAGES	21
2.3 ADDRESS MAP	23
2.4 ADDRESS ALLOCATION	25
2.4.1 Instrument data	25
2.4.2 Channel configuration data	26
CHANNEL 1	26
CHANNEL 2	27
CHANNEL 3	28
CHANNEL 4	29
CHANNEL 5	30
CHANNEL 6	31
CHANNEL 7	32
CHANNEL 8	33
CHANNEL 9	34
CHANNEL 10	35
CHANNEL 11	36
CHANNEL 12	37
2.4.3 Channel Run-Time data	38
CHANNEL 1	38
CHANNEL 2	38
CHANNEL 3	39
CHANNEL 4	39
CHANNEL 5	40
CHANNEL 6	40
CHANNEL 7	41
CHANNEL 8	41
CHANNEL 9	42
CHANNEL 10	42
CHANNEL 11	43
CHANNEL 12	43
2.4.4 Group data	44
GROUP 1	44
GROUP 2	45
GROUP 3	46
GROUP 4	47
GROUP 5	48
GROUP 6	49
2.4.5 Feature identification table (FIT)	50

Cont...

LIST OF CONTENTS (CONT.)

Section	Page
2.4.6 Indirection tables	50
2.4.7 IEEE 32-bit channel configuration data	53
CHANNEL 1	53
CHANNEL 2	53
CHANNEL 3	53
CHANNEL 4	54
CHANNEL 5	54
CHANNEL 6	54
CHANNEL 7	55
CHANNEL 8	55
CHANNEL 9	55
CHANNEL 10	56
CHANNEL 11	56
CHANNEL 12	56
2.4.8 IEEE Area Channel run-time data	57
CHANNEL 1	57
CHANNEL 2	57
CHANNEL 3	58
CHANNEL 4	58
CHANNEL 5	59
CHANNEL 6	59
CHANNEL 7	60
CHANNEL 8	60
CHANNEL 9	61
CHANNEL 10	61
CHANNEL 11	62
CHANNEL 12	62
2.4.9 Permanent ID table	63
2.5 DATA TRANSMISSION	63
FUNCTION CODES AND EXCEPTION CODES	63
TEXT STRINGS	63
2.5.1 Function code 03	64
REQUEST	64
RESPONSE	64
EXCEPTION RESPONSES	64
2.5.2 Function code 04	65
2.5.3 Function code 06	65
REQUEST	65
RESPONSE	65
EXCEPTION RESPONSES	65
2.5.4 Function code 08	65
2.5.5 Function code 16 (Hex 10)	66
REQUEST	66
RESPONSE	66
EXCEPTION RESPONSES	66

Cont...

LIST OF CONTENTS (CONT.)

Section	Page
3 MODBUS MASTER COMMS	67
3.1 INTRODUCTION	67
3.2 MASTER COMMS CONFIGURATION MENU	68
3.2.1 Configurable parameters	68
DETECT THIS SLAVE	69
DETECT ALL SLAVES	70
SHARE SOCKET	71
3.3 MASTER COMMS CHANNEL CONFIGURATION	72
3.3.1 Recorder/Data acquisition unit configurable parameters	72
TYPICAL RECORDER PARAMETERS	73
3.3.2 Controller parameters	74
TYPICAL CONTROLLER PARAMETERS	75
3.3.3 User defined registers	76
CONFIGURABLE PARAMETERS	76
3.3.4 Reading digital values	78
OPEN/CLOSED STRINGS	78
STATUS BITS	78
3.4 Demand Write Configuration	80
3.4.1 Writing to a known recorder	80
CONFIGURABLE ITEMS	81
DEMAND WRITE BUTTON	81
3.4.2 Writing to a specific register	82
CONFIGURABLE PARAMETERS	82
DEMAND WRITES WITH AUDIT TRAIL	83
3.5 OUTPUT CHANNELS	84
3.5.1 Configurable parameters	84
3.6 MASTER COMMS CHANNEL CONFIGURATION EXAMPLE	85
3.6.2 Master channel 1 setup	86
3.6.3 Master channel 2 setup	87
3.6.4 Master Output 1 setup	88
3.6.5 Slave Input Channel 1 setup	88
3.7 MASTER COMMS DIAGNOSTICS	89
4 SERIAL COMMUNICATIONS OPTION	90
4.1 INTRODUCTION	90
4.1.1 ASCII	90
4.1.2 MODBUS RTU	90
4.2 INSTALLATION	90
4.2.1 Installation rules:	91
4.2.2 Termination and biasing (Not EIA232)	91
4.3 CONFIGURATION	92
4.3.1 Configuration parameters	93
LINK ERROR COUNT	93
PROTOCOL	93
BAUD RATE	93
STOP BITS	93
PARITY	93
DATA BITS	93
TIMEOUT	93
MESSAGE START/END CHARACTERS	93
GROUP SELECTION	93
ENABLE ERROR CODE B	93
4.3.1 CONFIGURATION PARAMETERS (Cont.)	94
ENABLE TALK THROUGH	94
4.4 MESSAGING INFORMATION	94
4.4.1 Messaging Rules	94
INDEX	95

This page is deliberately left blank

1 REMOTE VIEWER

1.1 INTRODUCTION

This feature comes in two levels, called 'Full' and 'Lite'.

The 'Full' option allows full operation and configuration of the recorder, simultaneously, from up to four PCs which meet or exceed the minimum requirements listed below. When a change is being made to the configuration of the recorder by one Remote Viewer user ('client'), the message:

```
Feature Locked  
Another client (IP ADDRESS) has locked this feature.  
Wait for lock to be released and try again
```

appears on the screen of any other user who attempts to change the configuration. When changes are complete, the message:

```
Feature changed  
Synchronising data
```

appears on the screens of all clients (except that of the one making the change).

The 'Lite' option allows the user to view recorder standard screens, dynamically, on-line, from up to four PCs which meet or exceed the minimum requirements listed below.

The software is supplied on a CD ROM, which also includes PC Review, PC Configuration and Acrobat reader software and various manuals relevant to the recorder.

The Remote viewer software is suitable for any physical hardware configurations, some common examples being:

1. A single PC connected directly to a recorder.
2. Multiple PCs connected via a network to one or more recorders. (Each recorder can be accessed, simultaneously, by a maximum of four PCs, but one PC can look at a number of recorders depending on available memory. For example, a minimum specification computer (section 1.1.1) running Windows NT can 'look at' up to three recorders simultaneously.)
3. A single PC connected via a telephone line to a remote recorder.

This manual does not describe network setup in detail, as each network is different. In most cases, the help of the network administrator or supervisor will be required, for example, in the allocation of valid addresses and passwords.

Notes:

1. When logging in from a remote viewer, only users with 'Connect from Remote' enabled appear in the user list. See section 4.4.1 of the User Guide, supplied with this unit, for details.
 2. Full Remote Viewer requires some small amount of space on the PC disk. The message 'There appears to be no free disk space on the client. Create some space and run again.' appears if there is insufficient space.
 3. If an attempt is made to establish more than one Full Remote Viewer connection between a PC and the recorder, the message 'You are already running a Full Remote Viewer session to this instrument. The session will now run as a Lite Remote Viewer.' appears.
 4. If an attempt is made to establish a Full Remote Viewer connection using the 'anonymous' user name, the message 'You are authenticating Full Remote Viewer using the "anonymous" user name. This provides guest read only access. For Full remote Viewer you must use a different user name. Change and try again.' appears.
-

1.1.1 Minimum PC requirements

1. P90 running Windows 95/98/NT/2000/ME/XP
2. 32MB RAM
3. 50MB free hard disk space
4. Graphics drive capable of displaying > 256 colours (recommended)

SUPPORTED PDA CONFIGURATION

Compaq iPAQ 3850 with Jeode EVM version 1.9.

1.2 CONNECTION DETAILS

The connection to the recorder is terminated at the RJ45 connector located as shown in figures 2.2.1a, 2.2.1b). The other end of the cable may be terminated, for example, at a hub, a dial-up router or a PC, and it is up to the user to obtain a suitable cable (normally available from a computer supplier or electronic component distributor.)

Note: For direct connection between a PC and the recorder, a crossover cable is required. For all other connections, a 'straight-through' connection is required.

1.2.1 Direct PC connection

The RJ45 connector at the rear of the recorder is connected via a crossover cable to the PC network card connector.

1.2.2 PC To remote recorder

As shown in figure 1.2.2, one or more recorders' Ethernet connector can be connected to a Dial Up Router, plugged into a telephone socket. The PC must similarly be connected to a telephone socket via a modem (shown externally in the figure, but often built-in with modern computers.)

The dial-up router (available from computer suppliers etc.) has an associated telephone number, and can also have a security password system. Both the telephone number and any password(s) must be known to the PC user before any attempt at communication is made.

The PC can be set up to dial the number automatically, or the number may be dialled manually. Reference should be made to the computer documentation or help pages if necessary.

Once communication has been established, the software can be run.

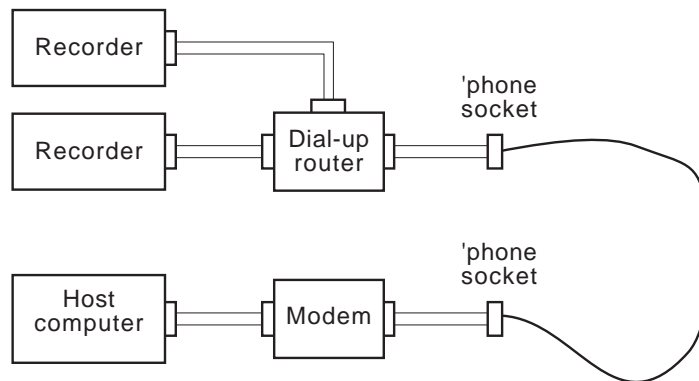

Figure 1.2.2 Remote connection example

1.2.3 Networked systems

For PCs and recorders connected into an internal network, it is necessary only to obtain an IP address (or name) and the required passwords in order to establish connections between the PC(s) and the recorder(s).

For PCs remote from a networked system which is permanently connected to the internet, it is necessary to obtain an IP address (or name) and the required passwords in order to establish connections between the PC and the recorder(s). In many cases it is also necessary that the internal network and 'firewall' (if such exists) be configured to allow access.

For PCs remote from a networked system which is not connected to the internet, a system similar to that shown in figure 1.2.2 is needed.

1.3 SOFTWARE INSTALLATION

Please refer to the CD box insert for details of software installation.

1.4 RECORDER CONFIGURATION

The recorder configuration is in three areas: Network, Options and Access,

1.4.1 Network

The Network key fields are fully described in Section 4.5 of the User Guide supplied with this unit.

1.4.2 Options

In order to make the option accessible, it must first be correctly entered in the Options Menu.

If the number of Remote Viewers displayed does not match the 'currently' number (if displayed), operation of the 'Autoconfigure' key will add the option to the database.

If all options are correctly entered, the 'Currently' fields and the Autoconfigure key do not appear.

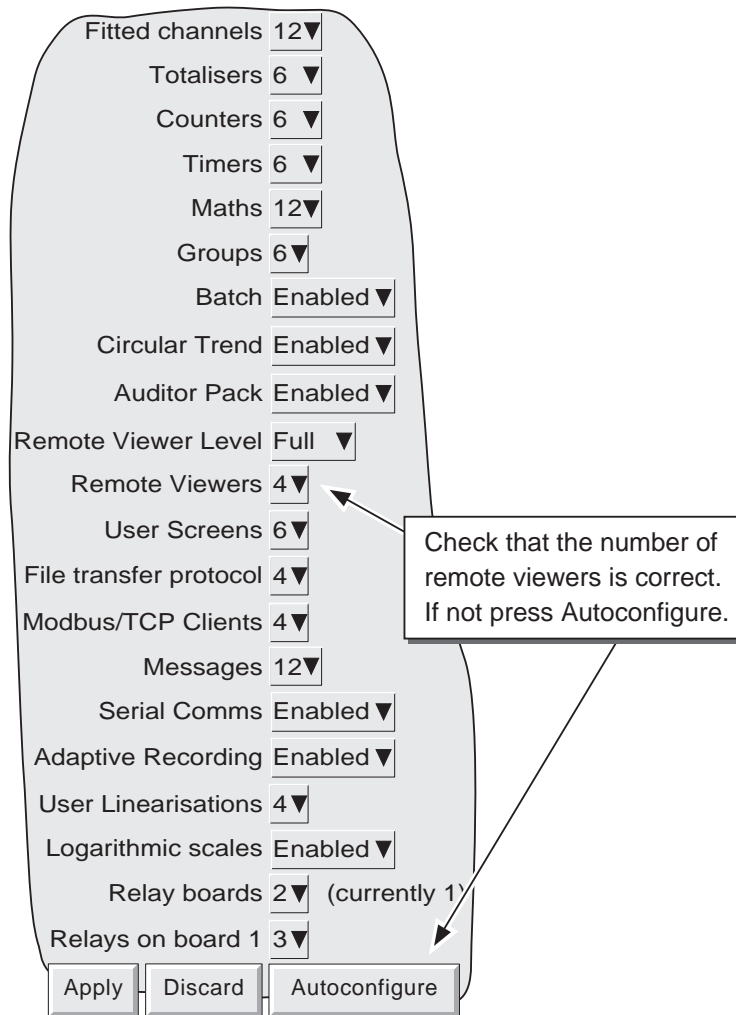

Figure 1.4.2 Options menu

1.4.3 Access

Each of the access levels and user IDs can have 'Connect from Remote' access enabled. When this box is checked, password entry fields appear as shown in figure 1.4.3. Initially, the Remote User Name is the same as the login name or access level. Enter the required User name and password (eight to 20 characters), then re-type the password to ensure it was entered correctly. This name and password are required when establishing connection with the host computer.

Access when	Fred ▼
New Password	**
Retype Password	**
Connect from remote	<input checked="" type="checkbox"/>
Remote user name	Fred
Remote password	
Retype remote password	
Login Disabled	<input type="checkbox"/>
Edit own Password	<input checked="" type="checkbox"/>
Change Alarm Setpoints	<input checked="" type="checkbox"/>

Figure 1.4.3 Remote user access fields

1.5 RUNNING THE PROGRAM

Initiate the program using the **START** button in the normal way.

Once the program starts, a Host name and User name will be requested as depicted in figure 1.5a.

Enter the Local host name (e.g. Andy136-4) found in the recorder Network/Name area, followed by a dot (full stop, period) followed by the domain name (e.g. FishesRus.co.uk) (also in the Network/Name area). These examples would result in an entry of Andy136-4.FishesRus.co.uk

Notes

- 1 If frequent use is to be made of this option, it is recommended that a 'short-cut' be created, and placed on the computer desktop. To create a new Remote Viewer link: right click on the desktop, left click 'New' in the pop up menu which appears, then left click on the Remote Viewer icon. When naming Remote Viewer files, the extension .uhv must be used.
 - 2 If there is no DNS server associated with the system, the IP address (found in the recorder Network/Address area) should be used instead.
 3. The PC locale setting (e.g. Daylight Saving Time) must match that set in the recorder (System/Locale) or the displayed time will be incorrect.
 4. If an attempt is made to start the program whilst another user is configuring the recorder, a 'Feature Locked' message appears: 'Another client (instrument) has locked this feature. Retrying until successful' appears. As soon as the other client 'Saves' the new recorder configuration, this message disappears and the program continues its startup.
-

Enter the user name as entered in the recorder's Security/Access/Remote user name field (section 1.4.3).

If password entry is not required, disable the tick box (goes blank), then press 'Start' to start running the program

If a password entry is required, ensure that the password required tick box is enabled (tick visible). Press 'Start', then enter the password (as entered in the Security/Access/Remote User Name/Remote password field), followed by carriage return to start running the program.

Clicking 'Start as Lite', allows the user to select the 'View only' version of the Remote Viewer. This has the advantage of faster operation.

Figure 1.5a Host /User name selection



Figure 1.5b Remote Viewer icon (approximation)

1.6 OPERATION

1.6.1 Display Modes

When the program starts, the Home page, as set up in Configuration\Views (section 4.3.4 of the User Guide supplied with this unit) is displayed on the computer screen. By click-dragging on the bottom right hand corner of the display, the page size can be sized as required. It is thus possible for the computer to log on to, say four, different recorders and to display their values simultaneously in different parts of the screen.

The up/down arrow keys allow the enabled display modes to be cycled through and the root menu 'Goto View' menu allows a specific display mode to be chosen for the current group. The Home display page can be returned-to at any time, by operating the Root Menu key followed by the Home key.

Note: Any changes to the recorder's group configuration are reflected immediately at the Remote Viewer screen.

1.6.2 Alarm acknowledgement

The alarm acknowledgement/read messages function are as described in section 3.1.3 of the User Guide supplied with this unit.

1.6.3 Status line

The status line at the top of the screen reflects the status of the instrument to which the recorder is connected - e.g. system messages, global alarm, FTP, clock etc.

1.6.4 Error messages

A number of error conditions may occur to prevent the remote viewer from 'viewing' the recorder. Any such conditions may be viewed by touching the alarm icon at the top of the screen, as described in section 3.1.3 of the User Guide supplied with this unit. The following messages can appear:

NETWORK CONNECTION HAS TIMED OUT

This message appears when no connection can be established between the remote viewer and the instrument. This might be caused by, for example, cable failure, the instrument's not being powered, network hardware failure etc.

UNABLE TO CONNECT TO HOST ...

Similar to the timeout message above, but with the additional cause: incorrect host address.

UNABLE TO RESOLVE HOSTNAME

Caused by an incorrect host address, or network failure.

FAILED TO AUTHENTICATE THE USER NAME ...

Caused by incorrect user name or password.

MAXIMUM REMOTE VIEWERS ALREADY CONNECTED TO ...

An attempt is being made to connect more remote viewers to the recorder than are configured in the Options menu.

THERE APPEARS TO BE NO FREE DISK SPACE ON ...

Appears if there is insufficient space on the PC hard disk.

YOU ARE ALREADY RUNNING A FULL REMOTE ...

Appears if the pc is already connected to the recorder and running Full Remote Viewer.

YOU ARE AUTHENTICATING FULL REMOTE ...

Only 'Lite' Remote viewer is accessible to users using 'Anonymous'.

2 MODBUS TCP SLAVE COMMS

2.1 INSTALLATION

The installation of the Modbus link consists of connecting a standard Ethernet cable between the RJ45 connector at the rear of the recorder either:

1. Directly to a host computer, using a crossover cable
2. To a host computer via a network, using a 'straight through' cable.

2.2 INTRODUCTION

MODBUS TCP allows one or more recorders to act as 'slave' devices to one or more host computers connected via the RJ45 connector at the rear of the recorder. Each recorder must have a unique Internet Protocol (IP) address, set up as described in Section 4.5 of the Installation and Operation Manual or User Guide supplied with this unit.

MODBUS TCP (Transmission Control Protocol) is a variant of the MODBUS family of communications protocols intended for supervision and control of automated equipment specifically covering the use of MODBUS messaging in an intranet or internet environment, using TCP/IP protocols. Much of the MODBUS detail in this manual is derived from the document openmbus.doc, available at <http://www.modicon.com/openmbus/standards/openmbus.doc>. The above mentioned document also includes implementation guidelines for users.

2.2.1 Function Codes

MODBUS function codes 3, 4, 6, 8 and 16, defined in table 2.2.1a below, are supported and are fully described in section 2.5, below.

Code	MODBUS definition	Description
03	Read holding registers	Reads the binary contents of holding registers. In this implementation, code 03 is identical with code 04.
04	Read input registers	Reads the binary contents of input registers. In this implementation, code 04 is identical with code 03.
06	Pre-set single register	Writes a single value to a single register.
08	Diagnostics	Obtains communications diagnostics information
16	Pre-set multiple Registers	Writes values to multiple holding registers

Table 2.2.1a MODBUS Function code definition

DIAGNOSTIC CODES

Function code 08, subfunction 00 (Return query data) echoes the query (Loop back).

2.2.1 FUNCTION CODES (Cont.)

EXCEPTION CODES

MODBUS TCP provides reserved codes used for exceptions. These codes provide error information relating to failed requests. Exceptions are signalled by hex 80 being added to the function code of the request, followed by one of the codes listed in table 2.2.1b, below.

		Code		MODBUS definition	Description
		Dec	Hex		
Modbus general	{	01	01	Illegal Function	An invalid function code was received
		02	02	Illegal Data Address	An invalid data address was received
		03	03	Illegal Data Value	An invalid data value was received
		04	04	Slave Device Failure	An unrecoverable error occurred in the recorder
Recorder specific	{	09	09	Illegal Sub Function	An invalid sub function was received.
		10	0A	Illegal login state	Security login required

Table 2.2.1b Exception codes

2.2.2 Data types

The following data types are supported:

- 1 2's complement signed 16-bit analogue values with implied decimal point. The decimal point position must be configured in both the recorder and the host computer.
- 2 2's complement, 16, 32 and 64 bit signed integers.
- 3 16-bit unsigned integer values.
- 4 32 bit IEEE Floating point values.
- 5 Strings of limited size, can be transferred across Modbus TCP in ASCII format using a single non-multiplexed set of consecutive registers.

DATA ENCODING

MODBUS uses what is called a 'Big endian' representation for addresses and data items. This means that when a numerical quantity larger than a single byte is transmitted, the most significant byte is sent first. For example a 32-bit hex value of 12345678 would be transmitted as 12, followed by 34, followed by 56 and finally 78.

2.2.3 Invalid multiple register writes

When a recorder receives a multi-register write request, it is possible that one or more requests will be rejected. Under such a circumstance, the recorder will accept all valid write requests and ignore any invalid writes. No error response is produced.

2.2.4 Security

The recorder has a local file in which are stored all users' login information, as set up in Security/Access configuration (section 4.4 of the User Guide supplied with this unit). Once the host computer has successfully established a connection, it must then supply the correct Username and Password. Should a host fail to login after three attempts, the recorder will terminate the connection.

This MODBUS security function can be enabled/disabled in the Operator/Config/Instrument menu (section 4.3 of the User Guide supplied with this unit).

Note: Modbus Security must be disabled in order for Modbus communications to be established. Once the Master is communicating with the Slave, Modbus security can be re-enabled, providing that the master has the correct remote user name and password data for the relevant slave. If this information is missing, all read/write requests will be ignored by the slave.

2.2.4 SECURITY (Cont.)

The following C++ code is intended for use in creating a suitable 16-bit encrypted register using an IP address and password:

```

/*-----
    FUNCTION : MB_Driver::encrypt
    DESCRIPTION : Create an encrypted value from a password string
    ARGUMENTS : pswd : Pointer to password from network file
                eKey : Pointer to eKey, usually I.P. address (must be 4 bytes)
    RETURN : result : A 16 bit value representing the encryption result
    NOTES : None
-----*/
Ushort MB_Driver::encrypt(cchar *pswd, cchar *ipAddr)
{
    Uchar key1;
    Uchar key2;
    Ushort dataLen;
    Uchar  ibyte;
    Ushort byteResult = 0;
    Uchar *encryptedData = NULL;
    Uchar eKeys[4];
    Ulong ipAddress;

    /* Convert ip address to an unsigned long value so that we can manipulate
       each of the 4 bytes, to be used as our private keys */
    ipAddress = inet_addr(ipAddr);

    // Now split the bytes up by copying the IP address into a byte array
    memcpy(eKeys, &ipAddress, sizeof(Ulong));

    // From the 4 bytes of the IP address create two exclusive keys
    key1 = eKeys[0] ^ eKeys[3];
    key2 = eKeys[1] ^ eKeys[2];

    // Calculate the length of the string to be encrypted
    dataLen = strlen(pswd);

    // Create some memory to store the new encrypted password
    encryptedData = (Uchar*) malloc(sizeof(Uchar)*dataLen);

    /* Copy the unencrypted password into a byte array, so we can use the
       character code as each byte value */
    memcpy(encryptedData, pswd, dataLen);

    /* Perform EXOR comparison between keys and raw data.
       Perform the operation on each byte using alternate key values
       starting at byte 1 with key 1 */
    for(ibyte=0; ibyte < dataLen;)
    {
        // EXOR with the key 1
        encryptedData[ibyte++] ^= key1;
    }
}

```

(Continued)

2.2.4 SECURITY (Cont.)

```

// Compare the next byte with key2
if(ibyte < dataLen)
{
    encryptedData[ibyte++] ^= key2;
}
}

/* Now EXOR each byte to the next byte until no more are available
if all goes well the last byte in the array should never change */
for(ibyte=0; ibyte < (dataLen-1); ibyte++)
{
    encryptedData[ibyte] = (encryptedData[ibyte] ^ encryptedData[ibyte+1]);
}

// Now add all the bytes together to get a 16 bit value result
for(ibyte=0; ibyte < dataLen; ibyte++)
{
    byteResult += encryptedData[ibyte];
}

// Return the encrypted string as a 16 bit value
return(byteResult);
}

```

Notes:

1. If login is accepted, a standard response is sent to the master
 2. If three invalid logins are sent, by the master, then an 'illegal address' exception code (2) is sent to the master.
-

2.2.4 SECURITY (Cont.)

TO SEND A LOGIN REQUEST

Request

Figure 2.2.4a shows data transmission sequence for sending a login request using the Ethernet network connection. Figure 2.2.4b is the same message for use with serial communications

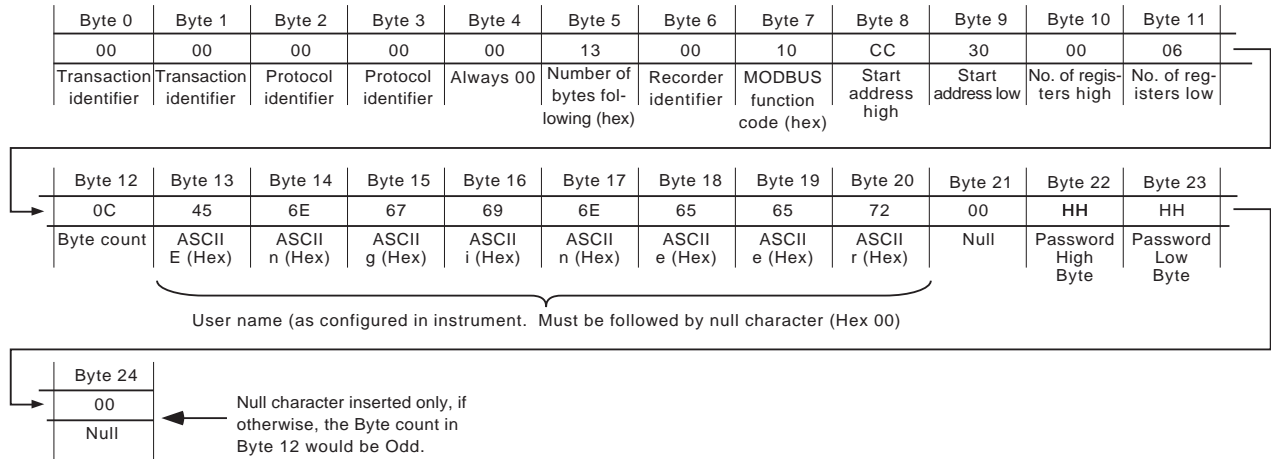

Figure 2.2.4a Login request via Ethernet (Modbus TCP)

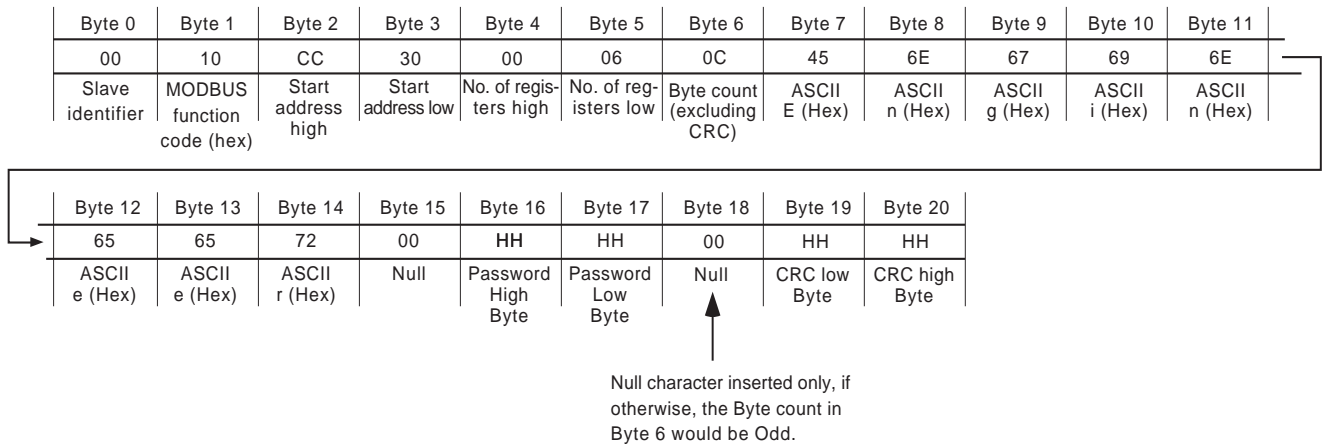

Figure 2.2.4b Login Request using a serial transmission line.

Notes:

- 1 The high and low password bytes are entered using the result of the encryption program above. If the password is blank, both High and Low Bytes must be 00 (null).
- 2 For successful login, the 'Connect from remote' item must be enabled (ref. 'Access levels in section 4.4.1 of the User Guide).

2.2.4 SECURITY (Cont.)

TO SEND A LOGIN REQUEST (Cont.)

Response

Figures 2.2.4c and 2.2.4d show response messages for successful and non-successful login attempts.

Byte 0	Byte 1	Byte 2	Byte 3	Byte 4	Byte 5	Byte 6	Byte 7	Byte 8	Byte 9	Byte 10	Byte 11
00	00	00	00	00	06	00	10	CC	30	00	05
Transaction identifier	Transaction identifier	Protocol identifier	Protocol identifier	Always 00	Number of bytes following (hex)	Recorder identifier	MODBUS function code (hex)	Start Address high	Start Address low	No. of registers high	No. of registers low

Figure 2.2.4c Response to a successful login attempt

Byte 0	Byte 1	Byte 2	Byte 3	Byte 4	Byte 5	Byte 6	Byte 7	Byte 8
00	00	00	00	00	04	00	90	02
Transaction identifier	Transaction identifier	Protocol identifier	Protocol identifier	Always 00	Number of bytes following (hex)	Recorder identifier	MODBUS function code+ MSB set (hex)	Exception code

Figure 2.2.4d Response after an unsuccessful login attempt

Notes

- 1 The above responses apply only to recorders fitted with software version 3.0 onwards, For versions prior to this, there is no response to a successful attempt, and the response after an unsuccessful attempt is similar to that shown in figure 2.2.4d, but with an exception code of 0A (Hex).
- 2 MSB = Most Significant Bit

2.3 ADDRESS MAP

Figure 2.3 shows the range of addresses allocated to various recorder functions. Each of these functions is described in detail in later sections.

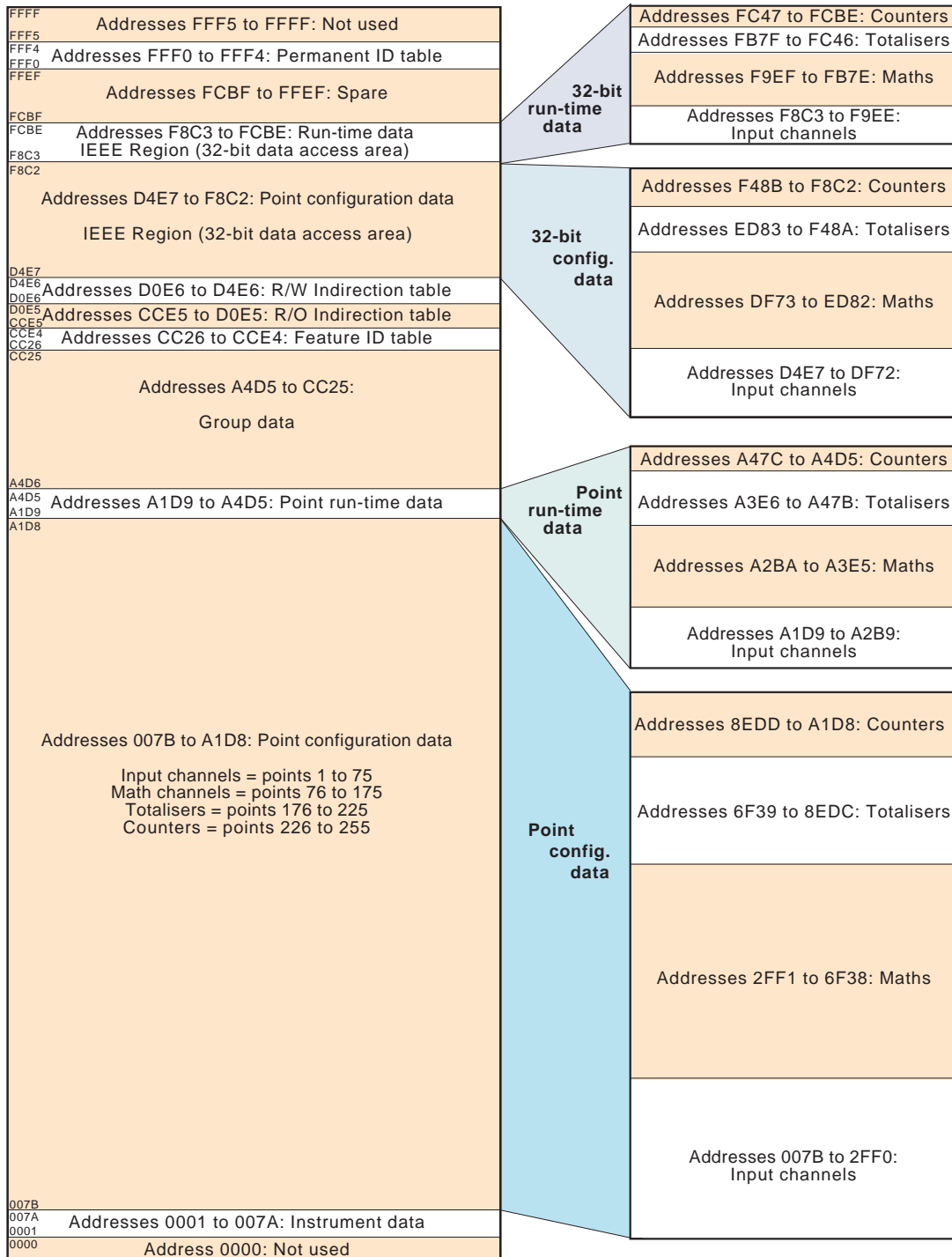

Figure 2.3 Address map representation

Notes:

- 1 All addresses in hexadecimal
- 2 Areas represent relative sizes, but are not to scale

2.3 ADDRESS MAP (Cont.)

The contents of each group can be determined by reading the relevant register number, as shown in [section 2.4.4](#), below. The table below is a decoder for the results.

For example, if a group has channels 1 to 6, maths channel 1 and totaliser three fitted, the results would be:

Register 1 = 63 (32 + 16 + 8 + 4 + 2 + 1) (channels 1 to 6)

Register 5 = 2048 (maths channel 1)

Register 12 = 2 (Totaliser 1)

All other register values = 0

Value if bit set →		1	2	4	8	16	32	64	128	256	512	1024	2048	4096	8192	16384	32768	
Bit number →		0	1	2	3	4	5	6	7	8	9	10	11	12	13	14	15	
Register Number	1	1	2	3	4	5	6	7	8	9	10	11	12	13	14	15	16	
	2	17	18	19	20	21	22	23	24	25	26	27	28	29	30	31	32	
	3	33	34	35	36	37	38	39	40	41	42	43	44	45	46	47	48	
	4	49	50	51	52	53	54	55	56	57	58	59	60	61	62	63	64	
	5	65	66	67	68	69	70	71	72	73	74	75	M1	M2	M3	M4	M5	
	6	M6	M7	M8	M9	M10	M11	M12	M13	M14	M15	M16	M17	M18	M19	M20	M21	
	7	M22	M23	M24	M25	M26	M27	M28	M29	M30	M31	M32	M33	M34	M35	M36	M37	
	8	M38	M39	M40	M41	M42	M43	M44	M45	M46	M47	M48	M49	M50	M51	M52	M53	
	9	M54	M55	M56	M57	M58	M59	M60	M61	M62	M63	M64	M65	M66	M67	M68	M69	
	10	M70	M71	M72	M73	M74	M75	M76	M77	M78	M79	M80	M81	M82	M83	M84	M85	
	11	M86	M87	M88	M89	M90	M91	M92	M93	M94	M95	M96	M97	M98	M99	M100	T1	
	12	T2	T3	T4	T5	T6	T7	T8	T9	T10	T11	T12	T13	T14	T15	T16	T17	
	13	T18	T19	T20	T21	T22	T23	T24	T25	T26	T27	T28	T29	T30	T31	T32	T33	
	14	T34	T35	T36	T37	T38	T39	T40	T41	T42	T43	T44	T45	T46	T47	T48	T49	
	15	T50	C1	C2	C3	C4	C5	C6	C7	C8	C9	C10	C11	C12	C13	C14	C15	
	16	C16	C17	C18	C19	C20	C21	C22	C23	C24	C25	C26	C27	C28	C29	C30		

Table 2.3 'Channels in group' interpretation

2.4 ADDRESS ALLOCATION

This section consists of a number of tables showing how the address space within the memory map is allocated. For full details of configuration parameters, refer to section 4 of the User Guide supplied with this unit. For convenience, the word ‘channel’ is used as an umbrella term for measuring points in general (i.e. input channels, maths channels, totalisers etc.).

The following ‘types’ are used in the tables.

- 1 Uint16 16 bit unsigned integer.
- 2 Uint32 32 bit unsigned integer.
- 3 Uint64 64 bit unsigned integer.
- 4 Scaled Double precision floating point value scaled to represent single precision 16-bit integer between – 32,767 and + 32,767.
- 5 Boolean Represented as a single 16 bit integer.
- 6 Enum Enumeration value - represented by a single 16 bit character.
- 7 16, 32 and 64-bit 2’s complement signed integers.

Note: When reading a Process Variable (PV) values, as ‘scaled’ integers the position of the decimal point is set by the ‘Max. Decimal Digits’ parameter in the relevant Channel’s Configuration. Only if the resulting value can be represented within 16 bit resolution (± 32767), will the value be transmitted accurately. For example, a value of 12.3456 needs more than 16-bit resolution, and the transmitted value would be the maximum value of 32767 (over range). Reducing the number of decimal places to three, for example (12.345) allows the value to be encoded as a 16-bit value which can be transmitted accurately.

2.4.1 Instrument data

Parameter Name	Description	Type	Access	Start Addr. Hex (Dec)	Register Length
Instrument type	Instrument type number	Uint16	Read only	0001 (1)	1
Instrument descriptor	Instrument descriptor (up to 20 characters)	String_20	Read only	0002 (2)	10
Reserved	Not used			000C (12)	10
Instrument status	Bit 0: 0 = RTC OK, 1 = RTC fail Bit 1: 0 = Floppy disk Ok, 1 = Disk worn Bit 2: 0 = Card/disk healthy, 1 = Corrupt Bit 3: 0 = Card/disk inserted, 1 = Missing Bit 4: 0 = Card/disk not full, 1 = Full Bit 5: 0 = Sys, history, user partition healthy 1 = Sys, history, user partition failure Bit 6: 0 = Data recording engine healthy 1 = Data recording engine failure Bit 7: 0 = No channel failures 1 = Channel failure	Uint16	Read only	0016 (22)	1
Config counter	Counts configuration changes. Powers up at zero, and is reset to zero at brown-out	Uint16	Read only	0017 (23)	1
Time	Current instrument time (UTC format)	Double	Read only	0018 (24)	4
Date	Current instrument date	Double	Read only	001C (28)	4
Global alarm acknowledge	A value of 1 acknowledges all alarms. Other values: no effect	Uint16	Write only	0020 (32)	1
Spare	Not used			0021 (33)	74
Reserved	Product version. Returns value 0001 (CNOMO*)	Uint 16	Read only	006B (107)	1
Spare	Not used			006C (108)	13
Reserved	Company ID. Returns value hex 0500 (CNOMO*)	Uint 16	Read only	0079 (121)	1
Reserved	Product ID. Returns model number in hex (CNOMO*)	Uint 16	Read only	007A (122)	1

* CNOMO = Comité de normalisation des moyens de production.

2.4.2 Channel configuration data

Note: A/B switching not supported for this software version.
Span, Zone, Colour etc. are all setting A

The following tables give hex addresses for channels 1 to 12, inclusive.

Generally: channel N parameter address = channel 1 parameter address + 162 (N-1) (decimal).

CHANNEL 1

Parameter Name	Description	Type	Access	Start Addr. Hex (Dec)	Register Length
Ch1 Span high	Upper span value (display full scale)	Scaled	Read only	007B (123)	1
Ch1 Span low	Lower span value (display 'zero')	Scaled	Read only	007C (124)	1
Ch1 Zone high	Zone high value (two decimal places)	Scaled	Read only	007D (125)	1
Ch1 Zone low	Zone low value (two decimal places)	Scaled	Read only	007E (126)	1
Ch1 PV type	Input type 1 = Analogue input 3 = Totaliser 2 = Maths 4 = Counter	Enum	Read only	007F (127)	1
Ch1 Decimal places	Number of decimal places (0 to 9) (used by all scaled parameters except where stated)	Uint16	Read only	0080 (128)	1
Ch1 Colour	Channel colour (0 to 55) (See Annex B for RGB definitions)	Enum	Read only	0081 (129)	1
Ch1 Units	Units string (up to five characters)	String_5	Read only	0082 (130)	3
Spare				0085 (133)	2
Ch1 Open string	Open Digital Input string (up to eight characters)	String_8	Read only	0087 (135)	4
Spare				008B (139)	4
Ch1 Close string	Closed Digital Input string (up to eight characters)	String_8	Read only	008F (143)	4
Spare				0093 (147)	4
Ch1 Descriptor	Channel descriptor (up to 20 characters)	String_20	Read only	0097 (151)	10
Spare				00A1 (161)	10
Ch1 No of alarms	Number of alarms on this channel	Uint16	Read only	00AB (171)	1
Ch1 PV format	0 = Numeric 1 = Digital strings	Enum	Read only	00AC (172)	1
Spare				00AD (173)	60
Ch1 Alarm 1 enable	Alarm 1 enable 0 = Off 2 = Latched 1 = Unlatched 3 = Trigger	Enum	Read only	00E9 (233)	1
Ch1 Alarm 1 type	Alarm 1 type 0 = Absolute low 1 = Absolute high 2 = Deviation in 3 = Deviation out 4 = Rate of change rise 5 = Rate of change fall	Enum	Read only	00EA (234)	1
Ch1 Alarm 1 setpoint	Trigger setpoint	Scaled	Read/Write	00EB (235)	1
Spare				00EC (236)	10
Ch1 Alarm 2 enable	Alarm 2 enable (As alarm 1 enable above)	Enum	Read only	00F6 (246)	1
Ch1 Alarm 2 type	Alarm 2 type (As alarm 1 type above)	Enum	Read only	00F7 (247)	1
Ch1 Alarm 2 setpoint	Trigger setpoint	Scaled	Read/Write	00F8 (248)	1
Spare				00F9 (249)	10
Ch1 Alarm 3 enable	Alarm 3 enable (As alarm 1 enable above)	Enum	Read only	0103 (259)	1
Ch1 Alarm 3 type	Alarm 3 type (As alarm 1 type above)	Enum	Read only	0104 (260)	1
Ch1 Alarm 3 setpoint	Trigger setpoint	Scaled	Read/Write	0105 (261)	1
Spare				0106 (262)	10
Ch1 Alarm 4 enable	Alarm 4 enable (As alarm 1 enable above)	Enum	Read only	0110 (272)	1
Ch1 Alarm 4 type	Alarm 4 type (As alarm 1 type above)	Enum	Read only	0111 (273)	1
Ch1 Alarm 4 setpoint	Trigger setpoint	Scaled	Read/Write	0112 (274)	1
Spare				0113 (275)	10

Notes:

1. Alarms 3 and 4 are available only for instruments fitted with 32MB DRAM.
2. For maths, totalisers and counters, see the relevant option description.

2.4.2 CHANNEL CONFIGURATION DATA (Cont.)

CHANNEL 2

Parameter Name	Description	Type	Access	Start Addr. Hex (Dec)	Register Length
Ch2 Span high	Upper span value (display full scale)	Scaled	Read only	011D (285)	1
Ch2 Span low	Lower span value (display 'zero')	Scaled	Read only	011E (286)	1
Ch2 Zone high	Zone high value (two decimal places)	Scaled	Read only	011F (287)	1
Ch2 Zone low	Zone low value (two decimal places)	Scaled	Read only	0120 (288)	1
Ch2 PV type	Input type 1 = Analogue input 3 = Totaliser 2 = Maths 4 = Counter	Enum	Read only	0121 (289)	1
Ch2 Decimal places	Number of decimal places (0 to 9) (used by all scaled parameters except where stated)	UInt16	Read only	0122 (290)	1
Ch2 Colour	Channel colour (0 to 55) (See Annex B for RGB definitions)	Enum	Read only	0123 (291)	1
Ch2 Units	Units string (up to five characters)	String_5	Read only	0124 (292)	3
Spare				0127 (295)	2
Ch2 Open string	Open Digital Input string (up to eight characters)	String_8	Read only	0129 (297)	4
Spare				012D (301)	4
Ch2 Close string	Closed Digital Input string (up to eight characters)	String_8	Read only	0131 (305)	4
Spare				0135 (309)	4
Ch2 Descriptor	Channel descriptor (up to 20 characters)	String_20	Read only	0139 (313)	10
Spare				0143 (323)	10
Ch2 No of alarms	Number of alarms on this channel (0 to 2)	UInt16	Read only	014D (333)	1
Ch2 PV format	0 = Numeric 1 = Digital strings	Enum	Read only	014E (334)	1
Spare				014F (335)	60
Ch2 Alarm 1 enable	Alarm 1 enable 0 = Off 2 = Latched 1 = Unlatched 3 = Trigger	Enum	Read only	018B (395)	1
Ch2 Alarm 1 type	Alarm 1 type 0 = Absolute low 1 = Absolute high 2 = Deviation in 3 = Deviation out 4 = Rate of change rise 5 = Rate of change fall	Enum	Read only	018C (396)	1
Ch2 Alarm 1 setpoint	Trigger setpoint	Scaled	Read/Write	018D (397)	1
Spare				018E (398)	10
Ch2 Alarm 2 enable	Alarm 2 enable (As alarm 1 enable, above)	Enum	Read only	0198 (408)	1
Ch2 Alarm 2 type	Alarm 2 type (As alarm 1 type, above)	Enum	Read only	0199 (409)	1
Ch2 Alarm 2 setpoint	Trigger setpoint	Scaled	Read/Write	019A (410)	1
Spare				019B (411)	10
Ch2 Alarm 3 enable	Alarm 3 enable (As alarm 1 enable above)	Enum	Read only	01A5 (421)	1
Ch2 Alarm 3 type	Alarm 3 type (As alarm 1 type above)	Enum	Read only	01A6 (422)	1
Ch2 Alarm 3 setpoint	Trigger setpoint	Scaled	Read/Write	01A7 (423)	1
Spare				01A8 (424)	10
Ch2 Alarm 4 enable	Alarm 4 enable (As alarm 1 enable above)	Enum	Read only	01B2 (434)	1
Ch2 Alarm 4 type	Alarm 4 type (As alarm 1 type above)	Enum	Read only	01B3 (435)	1
Ch2 Alarm 4 setpoint	Trigger setpoint	Scaled	Read/Write	01B4 (436)	1
Spare				01B5 (437)	10

Notes:

1. Alarms 3 and 4 are available only for instruments fitted with 32MB DRAM.
2. For maths, totalisers and counters, see the relevant option description.

2.4.2 CHANNEL CONFIGURATION DATA (Cont.)

CHANNEL 3

Parameter Name	Description	Type	Access	Start Addr. Hex (Dec)	Register Length
Ch3 Span high	Upper span value (display full scale)	Scaled	Read only	01BF (447)	1
Ch3 Span low	Lower span value (display 'zero')	Scaled	Read only	01C0 (448)	1
Ch3 Zone high	Zone high value (two decimal places)	Scaled	Read only	01C1 (449)	1
Ch3 Zone low	Zone low value (two decimal places)	Scaled	Read only	01C2 (450)	1
Ch3 PV type	Input type 1 = Analogue input 3 = Totaliser 2 = Maths 4 = Counter	Enum	Read only	01C3 (451)	1
Ch3 Decimal places	Number of decimal places (0 to 9) (used by all scaled parameters except where stated)	Uint16	Read only	01C4 (452)	1
Ch3 Colour	Channel colour (0 to 55) (See Annex B for RGB definitions)	Enum	Read only	01C5 (453)	1
Ch3 Units	Units string (up to five characters)	String_5	Read only	01C6 (454)	3
Spare				01C9 (457)	2
Ch3 Open string	Open Digital Input string (up to eight characters)	String_8	Read only	01CB (459)	4
Spare				01CF (463)	4
Ch3 Close string	Closed Digital Input string (up to eight characters)	String_8	Read only	01D3 (467)	4
Spare				01D7 (471)	4
Ch3 Descriptor	Channel descriptor (up to 20 characters)	String_20	Read only	01DB (475)	10
Spare				01E5 (485)	10
Ch3 No of alarms	Number of alarms on this channel (0 to 2)	Uint16	Read only	01EF (495)	1
Ch3 PV format	0 = Numeric 1 = Digital strings	Enum	Read only	01F0 (496)	1
Spare				01F1 (497)	60
Ch3 Alarm 1 enable	Alarm 1 enable 0 = Off 2 = Latched 1 = Unlatched 3 = Trigger	Enum	Read only	022D (557)	1
Ch3 Alarm 1 type	Alarm 1 type 0 = Absolute low 1 = Absolute high 2 = Deviation in 3 = Deviation out 4 = Rate of change rise 5 = Rate of change fall	Enum	Read only	022E (558)	1
Ch3 Alarm 1 setpoint	Trigger setpoint	Scaled	Read/Write	022F (559)	1
Spare				0230 (560)	10
Ch3 Alarm 2 enable	Alarm 2 enable (As alarm 1 enable, above)	Enum	Read only	023A (570)	1
Ch3 Alarm 2 type	Alarm 2 type (As alarm 1 type, above)	Enum	Read only	023B (571)	1
Ch3 Alarm 2 setpoint	Trigger setpoint	Scaled	Read/Write	023C (572)	1
Spare				023D (573)	10
Ch3 Alarm 3 enable	Alarm 3 enable (As alarm 1 enable above)	Enum	Read only	0247 (583)	1
Ch3 Alarm 3 type	Alarm 3 type (As alarm 1 type above)	Enum	Read only	0248 (584)	1
Ch3 Alarm 3 setpoint	Trigger setpoint	Scaled	Read/Write	0249 (585)	1
Spare				024A (586)	10
Ch3 Alarm 4 enable	Alarm 4 enable (As alarm 1 enable above)	Enum	Read only	0254 (596)	1
Ch3 Alarm 4 type	Alarm 4 type (As alarm 1 type above)	Enum	Read only	0255 (597)	1
Ch3 Alarm 4 setpoint	Trigger setpoint	Scaled	Read/Write	0256 (598)	1
Spare				0257 (599)	10

Notes:

1. Alarms 3 and 4 are available only for instruments fitted with 32MB DRAM.
2. For maths, totalisers and counters, see the relevant option description.

2.4.2 CHANNEL CONFIGURATION DATA (Cont.)

CHANNEL 4

Parameter Name	Description	Type	Access	Start Addr. Hex (Dec)	Register Length
Ch4 Span high	Upper span value (display full scale)	Scaled	Read only	0261 (609)	1
Ch4 Span low	Lower span value (display 'zero')	Scaled	Read only	0262 (610)	1
Ch4 Zone high	Zone high value (two decimal places)	Scaled	Read only	0263 (611)	1
Ch4 Zone low	Zone low value (two decimal places)	Scaled	Read only	0264 (612)	1
Ch4 PV type	Input type 1 = Analogue input 3 = Totaliser 2 = Maths 4 = Counter	Enum	Read only	0265 (613)	1
Ch4 Decimal places	Number of decimal places (0 to 9) (used by all scaled parameters except where stated)	Uint16	Read only	0266 (614)	1
Ch4 Colour	Channel colour (0 to 55) (See Annex B for RGB definitions)	Enum	Read only	0267 (615)	1
Ch4 Units	Units string (up to five characters)	String_5	Read only	0268 (616)	3
Spare				026B (619)	2
Ch4 Open string	Open Digital Input string (up to eight characters)	String_8	Read only	026D (621)	4
Spare				0271 (625)	4
Ch4 Close string	Closed Digital Input string (up to eight characters)	String_8	Read only	0275 (629)	4
Spare				0279 (633)	4
Ch4 Descriptor	Channel descriptor (up to 20 characters)	String_20	Read only	027D (637)	10
Spare				0287 (647)	10
Ch4 No of alarms	Number of alarms on this channel (0 to 2)	Uint16	Read only	0291 (657)	1
Ch4 PV format	0 = Numeric 1 = Digital strings	Enum	Read only	0292 (658)	1
Spare				0293 (659)	60
Ch4 Alarm 1 enable	Alarm 1 enable 0 = Off 2 = Latched 1 = Unlatched 3 = Trigger	Enum	Read only	02CF (719)	1
Ch4 Alarm 1 type	Alarm 1 type 0 = Absolute low 1 = Absolute high 2 = Deviation in 3 = Deviation out 4 = Rate of change rise 5 = Rate of change fall	Enum	Read only	02D0 (720)	1
Ch4 Alarm 1 setpoint	Trigger setpoint	Scaled	Read/Write	02D1 (721)	1
Spare				02D2 (722)	10
Ch4 Alarm 2 enable	Alarm 2 enable (As alarm 1 enable, above)	Enum	Read only	02DC (732)	1
Ch4 Alarm 2 type	Alarm 2 type (As alarm 1 type, above)	Enum	Read only	02DD (733)	1
Ch4 Alarm 2 setpoint	Trigger setpoint	Scaled	Read/Write	02DE (734)	1
Spare				02DF (735)	10
Ch4 Alarm 3 enable	Alarm 3 enable (As alarm 1 enable above)	Enum	Read only	02E9 (745)	1
Ch4 Alarm 3 type	Alarm 3 type (As alarm 1 type above)	Enum	Read only	02EA (746)	1
Ch4 Alarm 3 setpoint	Trigger setpoint	Scaled	Read/Write	02EB (747)	1
Spare				02EC (748)	10
Ch4 Alarm 4 enable	Alarm 4 enable (As alarm 1 enable above)	Enum	Read only	02F6 (758)	1
Ch4 Alarm 4 type	Alarm 4 type (As alarm 1 type above)	Enum	Read only	02F7 (759)	1
Ch4 Alarm 4 setpoint	Trigger setpoint	Scaled	Read/Write	02F8 (760)	1
Spare				02F9 (761)	10

Notes:

1. Alarms 3 and 4 are available only for instruments fitted with 32MB DRAM.
2. For maths, totalisers and counters, see the relevant option description.

2.4.2 CHANNEL CONFIGURATION DATA (Cont.)

CHANNEL 5

Parameter Name	Description	Type	Access	Start Addr. Hex (Dec)	Register Length
Ch5 Span high	Upper span value (display full scale)	Scaled	Read only	0303 (771)	1
Ch5 Span low	Lower span value (display 'zero')	Scaled	Read only	0304 (772)	1
Ch5 Zone high	Zone high value (two decimal places)	Scaled	Read only	0305 (773)	1
Ch5 Zone low	Zone low value (two decimal places)	Scaled	Read only	0306 (774)	1
Ch5 PV type	Input type 1 = Analogue input 3 = Totaliser 2 = Maths 4 = Counter	Enum	Read only	0307 (775)	1
Ch5 Decimal places	Number of decimal places (0 to 9) (used by all scaled parameters except where stated)	Uint16	Read only	0308 (776)	1
Ch5 Colour	Channel colour (0 to 55) (See Annex B for RGB definitions)	Enum	Read only	0309 (777)	1
Ch5 Units	Units string (up to five characters)	String_5	Read only	030A (778)	3
Spare				030D (781)	2
Ch5 Open string	Open Digital Input string (up to eight characters)	String_8	Read only	030F (783)	4
Spare				0313 (787)	4
Ch5 Close string	Closed Digital Input string (up to eight characters)	String_8	Read only	0317 (791)	4
Spare				031B (795)	4
Ch5 Descriptor	Channel descriptor (up to 20 characters)	String_20	Read only	031F (799)	10
Spare				0329 (809)	10
Ch5 No of alarms	Number of alarms on this channel (0 to 2)	Uint16	Read only	0333 (819)	1
Ch5 PV format	0 = Numeric 1 = Digital strings	Enum	Read only	0334 (820)	1
Spare				0335 (821)	60
Ch5 Alarm 1 enable	Alarm 1 enable 0 = Off 2 = Latched 1 = Unlatched 3 = Trigger	Enum	Read only	0371 (881)	1
Ch5 Alarm 1 type	Alarm 1 type 0 = Absolute low 1 = Absolute high 2 = Deviation in 3 = Deviation out 4 = Rate of change rise 5 = Rate of change fall	Enum	Read only	0372 (882)	1
Ch5 Alarm 1 setpoint	Trigger setpoint	Scaled	Read/Write	0373 (883)	1
Spare				0374 (884)	10
Ch5 Alarm 2 enable	Alarm 2 enable (As alarm 1 enable, above)	Enum	Read only	037E (894)	1
Ch5 Alarm 2 type	Alarm 2 type (As alarm 1 type, above)	Enum	Read only	037F (895)	1
Ch5 Alarm 2 setpoint	Trigger setpoint	Scaled	Read/Write	0380 (896)	1
Spare				0381 (897)	10
Ch5 Alarm 3 enable	Alarm 3 enable (As alarm 1 enable above)	Enum	Read only	02E9 (907)	1
Ch5 Alarm 3 type	Alarm 3 type (As alarm 1 type above)	Enum	Read only	02EA (908)	1
Ch5 Alarm 3 setpoint	Trigger setpoint	Scaled	Read/Write	02EB (909)	1
Spare				02EC (910)	10
Ch5 Alarm 4 enable	Alarm 4 enable (As alarm 1 enable above)	Enum	Read only	02F6 (920)	1
Ch5 Alarm 4 type	Alarm 4 type (As alarm 1 type above)	Enum	Read only	02F7 (921)	1
Ch5 Alarm 4 setpoint	Trigger setpoint	Scaled	Read/Write	02F8 (922)	1
Spare				02F9 (923)	10

Notes:

1. Alarms 3 and 4 are available only for instruments fitted with 32MB DRAM.
2. For maths, totalisers and counters, see the relevant option description.

2.4.2 CHANNEL CONFIGURATION DATA (Cont.)

CHANNEL 6

Parameter Name	Description	Type	Access	Start Addr. Hex (Dec)	Register Length
Ch6 Span high	Upper span value (display full scale)	Scaled	Read only	03A5 (933)	1
Ch6 Span low	Lower span value (display 'zero')	Scaled	Read only	03A6 (934)	1
Ch6 Zone high	Zone high value (two decimal places)	Scaled	Read only	03A7 (935)	1
Ch6 Zone low	Zone low value (two decimal places)	Scaled	Read only	03A8 (936)	1
Ch6 PV type	Input type 1 = Analogue input 3 = Totaliser 2 = Maths 4 = Counter	Enum	Read only	03A9 (937)	1
Ch6 Decimal places	Number of decimal places (0 to 9) (used by all scaled parameters except where stated)	Uint16	Read only	03AA (938)	1
Ch6 Colour	Channel colour (0 to 55) (See Annex B for RGB definitions)	Enum	Read only	03AB (939)	1
Ch6 Units	Units string (up to five characters)	String_5	Read only	03AC (940)	3
Spare				03AF (943)	2
Ch6 Open string	Open Digital Input string (up to eight characters)	String_8	Read only	03B1 (945)	4
Spare				03B5 (949)	4
Ch6 Close string	Closed Digital Input string (up to eight characters)	String_8	Read only	03B9 (953)	4
Spare				03BD (957)	4
Ch6 Descriptor	Channel descriptor (up to 20 characters)	String_20	Read only	03C1 (961)	10
Spare				03CB (971)	10
Ch6 No of alarms	Number of alarms on this channel (0 to 2)	Uint16	Read only	03D5 (981)	1
Ch6 PV format	0 = Numeric 1 = Digital strings	Enum	Read only	03D6 (982)	1
Spare				03D7 (983)	60
Ch6 Alarm 1 enable	Alarm 1 enable 0 = Off 2 = Latched 1 = Unlatched 3 = Trigger	Enum	Read only	0413 (1043)	1
Ch6 Alarm 1 type	Alarm 1 type 0 = Absolute low 1 = Absolute high 2 = Deviation in 3 = Deviation out 4 = Rate of change rise 5 = Rate of change fall	Enum	Read only	0414 (1044)	1
Ch6 Alarm 1 setpoint	Trigger setpoint	Scaled	Read/Write	0415 (1045)	1
Spare				0416 (1046)	10
Ch6 Alarm 2 enable	Alarm 2 enable (As alarm 1 enable, above)	Enum	Read only	0420 (1056)	1
Ch6 Alarm 2 type	Alarm 2 type (As alarm 1 type, above)	Enum	Read only	0421 (1057)	1
Ch6 Alarm 2 setpoint	Trigger setpoint	Scaled	Read/Write	0422 (1058)	1
Spare				0423 (1059)	10
Ch6 Alarm 3 enable	Alarm 3 enable (As alarm 1 enable above)	Enum	Read only	042D (1069)	1
Ch6 Alarm 3 type	Alarm 3 type (As alarm 1 type above)	Enum	Read only	042E (1070)	1
Ch6 Alarm 3 setpoint	Trigger setpoint	Scaled	Read/Write	042F (1071)	1
Spare				0430 (1072)	10
Ch6 Alarm 4 enable	Alarm 4 enable (As alarm 1 enable above)	Enum	Read only	043A (1082)	1
Ch6 Alarm 4 type	Alarm 4 type (As alarm 1 type above)	Enum	Read only	043B (1083)	1
Ch6 Alarm 4 setpoint	Trigger setpoint	Scaled	Read/Write	043C (1084)	1
Spare				043D (1085)	10

Notes:

1. Alarms 3 and 4 are available only for instruments fitted with 32MB DRAM.
2. For maths, totalisers and counters, see the relevant option description.

2.4.2 CHANNEL CONFIGURATION DATA (Cont.)

CHANNEL 7

Parameter Name	Description	Type	Access	Start Addr. Hex (Dec)	Register Length
Ch7 Span high	Upper span value (display full scale)	Scaled	Read only	0447 (1095)	1
Ch7 Span low	Lower span value (display 'zero')	Scaled	Read only	0448 (1096)	1
Ch7 Zone high	Zone high value (two decimal places)	Scaled	Read only	0449 (1097)	1
Ch7 Zone low	Zone low value (two decimal places)	Scaled	Read only	044A (1098)	1
Ch7 PV type	Input type 1 = Analogue input 3 = Totaliser 2 = Maths 4 = Counter	Enum	Read only	044B (1099)	1
Ch7 Decimal places	Number of decimal places (0 to 9) (used by all scaled parameters except where stated)	Uint16	Read only	044C (1100)	1
Ch7 Colour	Channel colour (0 to 55) (See Annex B for RGB definitions)	Enum	Read only	044D (1101)	1
Ch7 Units	Units string (up to five characters)	String_5	Read only	044E (1102)	3
Spare				0451 (1105)	2
Ch7 Open string	Open Digital Input string (up to eight characters)	String_8	Read only	0453 (1107)	4
Spare				0457 (1111)	4
Ch7 Close string	Closed Digital Input string (up to eight characters)	String_8	Read only	045B (1115)	4
Spare				045F (1119)	4
Ch7 Descriptor	Channel descriptor (up to 20 characters)	String_20	Read only	0463 (1123)	10
Spare				046D (1133)	10
Ch7 No of alarms	Number of alarms on this channel (0 to 2)	Uint16	Read only	0477 (1143)	1
Ch7 PV format	0 = Numeric 1 = Digital strings	Enum	Read only	0478 (1144)	1
Spare				0479 (1145)	60
Ch7 Alarm 1 enable	Alarm 1 enable 0 = Off 2 = Latched 1 = Unlatched 3 = Trigger	Enum	Read only	04B5 (1205)	1
Ch7 Alarm 1 type	Alarm 1 type 0 = Absolute low 1 = Absolute high 2 = Deviation in 3 = Deviation out 4 = Rate of change rise 5 = Rate of change fall	Enum	Read only	04B6 (1206)	1
Ch7 Alarm 1 setpoint	Trigger setpoint	Scaled	Read/Write	04B7 (1207)	1
Spare				04B8 (1208)	10
Ch7 Alarm 2 enable	Alarm 2 enable (As alarm 1 enable, above)	Enum	Read only	04C2 (1218)	1
Ch7 Alarm 2 type	Alarm 2 type (As alarm 1 type, above)	Enum	Read only	04C3 (1219)	1
Ch7 Alarm 2 setpoint	Trigger setpoint	Scaled	Read/Write	04C4 (1220)	1
Spare				04C5 (1221)	10
Ch7 Alarm 3 enable	Alarm 3 enable (As alarm 1 enable above)	Enum	Read only	04CF (1231)	1
Ch7 Alarm 3 type	Alarm 3 type (As alarm 1 type above)	Enum	Read only	04D0 (1232)	1
Ch7 Alarm 3 setpoint	Trigger setpoint	Scaled	Read/Write	04D1 (1233)	1
Spare				04D2 (1234)	10
Ch7 Alarm 4 enable	Alarm 4 enable (As alarm 1 enable above)	Enum	Read only	04DC (1244)	1
Ch7 Alarm 4 type	Alarm 4 type (As alarm 1 type above)	Enum	Read only	04DD (1245)	1
Ch7 Alarm 4 setpoint	Trigger setpoint	Scaled	Read/Write	04DE (1246)	1
Spare				04DF (1247)	10

Notes:

1. Alarms 3 and 4 are available only for instruments fitted with 32MB DRAM.
2. For maths, totalisers and counters, see the relevant option description.

2.4.2 CHANNEL CONFIGURATION DATA (Cont.)

CHANNEL 8

Parameter Name	Description	Type	Access	Start Addr. Hex (Dec)	Register Length
Ch8 Span high	Upper span value (display full scale)	Scaled	Read only	04E9 (1257)	1
Ch8 Span low	Lower span value (display 'zero')	Scaled	Read only	04EA (1258)	1
Ch8 Zone high	Zone high value (two decimal places)	Scaled	Read only	04EB (1259)	1
Ch8 Zone low	Zone low value (two decimal places)	Scaled	Read only	04EC (1260)	1
Ch8 PV type	Input type 1 = Analogue input 3 = Totaliser 2 = Maths 4 = Counter	Enum	Read only	04ED (1261)	1
Ch8 Decimal places	Number of decimal places (0 to 9) (used by all scaled parameters except where stated)	UInt16	Read only	04EE (1262)	1
Ch8 Colour	Channel colour (0 to 55) (See Annex B for RGB definitions)	Enum	Read only	04EF (1263)	1
Ch8 Units	Units string (up to five characters)	String_5	Read only	04F0 (1264)	3
Spare				04F3 (1267)	2
Ch8 Open string	Open Digital Input string (up to eight characters)	String_8	Read only	04F5 (1269)	4
Spare				04F9 (1273)	4
Ch8 Close string	Closed Digital Input string (up to eight characters)	String_8	Read only	04FD (1277)	4
Spare				0501 (1281)	4
Ch8 Descriptor	Channel descriptor (up to 20 characters)	String_20	Read only	0505 (1285)	10
Spare				050F (1295)	10
Ch8 No of alarms	Number of alarms on this channel (0 to 2)	UInt16	Read only	0519 (1305)	1
Ch8 PV format	0 = Numeric 1 = Digital strings	Enum	Read only	051A (1306)	1
Spare				051B (1307)	60
Ch8 Alarm 1 enable	Alarm 1 enable 0 = Off 2 = Latched 1 = Unlatched 3 = Trigger	Enum	Read only	0557 (1367)	1
Ch8 Alarm 1 type	Alarm 1 type 0 = Absolute low 1 = Absolute high 2 = Deviation in 3 = Deviation out 4 = Rate of change rise 5 = Rate of change fall	Enum	Read only	0558 (1368)	1
Ch8 Alarm 1 setpoint	Trigger setpoint	Scaled	Read/Write	0559 (1369)	1
Spare				055A (1370)	10
Ch8 Alarm 2 enable	Alarm 2 enable (As alarm 1 enable, above)	Enum	Read only	0564 (1380)	1
Ch8 Alarm 2 type	Alarm 2 type (As alarm 1 type, above)	Enum	Read only	0565 (1381)	1
Ch8 Alarm 2 setpoint	Trigger setpoint	Scaled	Read/Write	0566 (1382)	1
Spare				0567 (1383)	10
Ch8 Alarm 3 enable	Alarm 3 enable (As alarm 1 enable above)	Enum	Read only	0571(1393)	1
Ch8 Alarm 3 type	Alarm 3 type (As alarm 1 type above)	Enum	Read only	0572 (1394)	1
Ch8 Alarm 3 setpoint	Trigger setpoint	Scaled	Read/Write	0573 (1395)	1
Spare				0574 (1396)	10
Ch8 Alarm 4 enable	Alarm 4 enable (As alarm 1 enable above)	Enum	Read only	057E (1406)	1
Ch8 Alarm 4 type	Alarm 4 type (As alarm 1 type above)	Enum	Read only	057F (1407)	1
Ch8 Alarm 4 setpoint	Trigger setpoint	Scaled	Read/Write	0580 (1408)	1
Spare				0581 (1409)	10

Notes:

1. Alarms 3 and 4 are available only for instruments fitted with 32MB DRAM.
2. For maths, totalisers and counters, see the relevant option description.

2.4.2 CHANNEL CONFIGURATION DATA (Cont.)

CHANNEL 9

Parameter Name	Description	Type	Access	Start Addr. Hex (Dec)	Register Length
Ch9 Span high	Upper span value (display full scale)	Scaled	Read only	058B (1419)	1
Ch9 Span low	Lower span value (display 'zero')	Scaled	Read only	058C (1420)	1
Ch9 Zone high	Zone high value (two decimal places)	Scaled	Read only	058D (1421)	1
Ch9 Zone low	Zone low value (two decimal places)	Scaled	Read only	058E (1422)	1
Ch9 PV type	Input type 1 = Analogue input 3 = Totaliser 2 = Maths 4 = Counter	Enum	Read only	058F (1423)	1
Ch9 Decimal places	Number of decimal places (0 to 9) (used by all scaled parameters except where stated)	Uint16	Read only	0590 (1424)	1
Ch9 Colour	Channel colour (0 to 55) (See Annex B for RGB definitions)	Enum	Read only	0591 (1425)	1
Ch9 Units	Units string (up to five characters)	String_5	Read only	0592 (1426)	3
Spare				0595 (1429)	2
Ch9 Open string	Open Digital Input string (up to eight characters)	String_8	Read only	0597 (1431)	4
Spare				059B (1435)	4
Ch9 Close string	Closed Digital Input string (up to eight characters)	String_8	Read only	059F (1439)	4
Spare				05A3 (1443)	4
Ch9 Descriptor	Channel descriptor (up to 20 characters)	String_20	Read only	05A7 (1447)	10
Spare				05B1 (1457)	10
Ch9 No of alarms	Number of alarms on this channel (0 to 2)	Uint16	Read only	05BB (1467)	1
Ch9 PV format	0 = Numeric 1 = Digital strings	Enum	Read only	05BC (1468)	1
Spare				05BD (1469)	60
Ch9 Alarm 1 enable	Alarm 1 enable 0 = Off 2 = Latched 1 = Unlatched 3 = Trigger	Enum	Read only	05F9 (1529)	1
Ch9 Alarm 1 type	Alarm 1 type 0 = Absolute low 1 = Absolute high 2 = Deviation in 3 = Deviation out 4 = Rate of change rise 5 = Rate of change fall	Enum	Read only	05FA (1530)	1
Ch9 Alarm 1 setpoint	Trigger setpoint	Scaled	Read/Write	05FB (1531)	1
Spare				05FC (1532)	10
Ch9 Alarm 2 enable	Alarm 2 enable (As alarm 1 enable, above)	Enum	Read only	0606 (1542)	1
Ch9 Alarm 2 type	Alarm 2 type (As alarm 1 type, above)	Enum	Read only	0607 (1543)	1
Ch9 Alarm 2 setpoint	Trigger setpoint	Scaled	Read/Write	0608 (1544)	1
Spare				0609 (1545)	10
Ch9 Alarm 3 enable	Alarm 3 enable (As alarm 1 enable above)	Enum	Read only	0613(1555)	1
Ch9 Alarm 3 type	Alarm 3 type (As alarm 1 type above)	Enum	Read only	0614 (1556)	1
Ch9 Alarm 3 setpoint	Trigger setpoint	Scaled	Read/Write	0615 (1557)	1
Spare				0616 (1558)	10
Ch9 Alarm 4 enable	Alarm 4 enable (As alarm 1 enable above)	Enum	Read only	0620 (1568)	1
Ch9 Alarm 4 type	Alarm 4 type (As alarm 1 type above)	Enum	Read only	0621 (1569)	1
Ch9 Alarm 4 setpoint	Trigger setpoint	Scaled	Read/Write	0622 (1570)	1
Spare				0623 (1571)	10

Notes:

1. Alarms 3 and 4 are available only for instruments fitted with 32MB DRAM.
2. For maths, totalisers and counters, see the relevant option description.

2.4.2 CHANNEL CONFIGURATION DATA (Cont.)

CHANNEL 10

Parameter Name	Description	Type	Access	Start Addr. Hex (Dec)	Register Length
Ch10 Span high	Upper span value (display full scale)	Scaled	Read only	062D (1581)	1
Ch10 Span low	Lower span value (display 'zero')	Scaled	Read only	062E (1582)	1
Ch10 Zone high	Zone high value (two decimal places)	Scaled	Read only	062F (1583)	1
Ch10 Zone low	Zone low value (two decimal places)	Scaled	Read only	0630 (1584)	1
Ch10 PV type	Input type 1 = Analogue input 3 = Totaliser 2 = Maths 4 = Counter	Enum	Read only	0631 (1585)	1
Ch10 Decimal places	Number of decimal places (0 to 9) (used by all scaled parameters except where stated)	Uint16	Read only	0632 (1586)	1
Ch10 Colour	Channel colour (0 to 55) (See Annex B for RGB definitions)	Enum	Read only	0633 (1587)	1
Ch10 Units	Units string (up to five characters)	String_5	Read only	0634 (1588)	3
Spare				0637 (1591)	2
Ch10 Open string	Open Digital Input string (up to eight characters)	String_8	Read only	0639 (1593)	4
Spare				063D (1597)	4
Ch10 Close string	Closed Digital Input string (up to eight characters)	String_8	Read only	0641 (1601)	4
Spare				0645 (1605)	4
Ch10 Descriptor	Channel descriptor (up to 20 characters)	String_20	Read only	0649 (1609)	10
Spare				0653 (1619)	10
Ch10 No of alarms	Number of alarms on this channel (0 to 2)	Uint16	Read only	065D (1629)	1
Ch10 PV format	0 = Numeric 1 = Digital strings	Enum	Read only	065E (1630)	1
Spare				065F (1631)	60
Ch10 Alarm 1 enable	Alarm 1 enable 0 = Off 2 = Latched 1 = Unlatched 3 = Trigger	Enum	Read only	069B (1691)	1
Ch10 Alarm 1 type	Alarm 1 type 0 = Absolute low 1 = Absolute high 2 = Deviation in 3 = Deviation out 4 = Rate of change rise 5 = Rate of change fall	Enum	Read only	069C (1692)	1
Ch10 Alarm 1 setpoint	Trigger setpoint	Scaled	Read/Write	069D (1693)	1
Spare				069E (1694)	10
Ch10 Alarm 2 enable	Alarm 2 enable (As alarm 1 enable, above)	Enum	Read only	06A8 (1704)	1
Ch10 Alarm 2 type	Alarm 2 type (As alarm 1 type, above)	Enum	Read only	06A9 (1705)	1
Ch10 Alarm 2 setpoint	Trigger setpoint	Scaled	Read/Write	06AA (1706)	1
Spare				06AB (1707)	10
Ch10 Alarm 3 enable	Alarm 3 enable (As alarm 1 enable above)	Enum	Read only	06B5(1717)	1
Ch10 Alarm 3 type	Alarm 3 type (As alarm 1 type above)	Enum	Read only	06B6(1718)	1
Ch10 Alarm 3 setpoint	Trigger setpoint	Scaled	Read/Write	06B7 (1719)	1
Spare				06B8 (1720)	10
Ch10 Alarm 4 enable	Alarm 4 enable (As alarm 1 enable above)	Enum	Read only	06C2 (1730)	1
Ch10 Alarm 4 type	Alarm 4 type (As alarm 1 type above)	Enum	Read only	06C3 (1731)	1
Ch10 Alarm 4 setpoint	Trigger setpoint	Scaled	Read/Write	06C4 (1732)	1
Spare				06C5 (1733)	10

Notes:

- Alarms 3 and 4 are available only for instruments fitted with 32MB DRAM.
- For maths, totalisers and counters, see the relevant option description.

2.4.2 CHANNEL CONFIGURATION DATA (Cont.)

CHANNEL 11

Parameter Name	Description	Type	Access	Start Addr. Hex (Dec)	Register Length
Ch11 Span high	Upper span value (display full scale)	Scaled	Read only	06CF (1743)	1
Ch11 Span low	Lower span value (display 'zero')	Scaled	Read only	06D0 (1744)	1
Ch11 Zone high	Zone high value (two decimal places)	Scaled	Read only	06D1 (1745)	1
Ch11 Zone low	Zone low value (two decimal places)	Scaled	Read only	06D2 (1746)	1
Ch11 PV type	Input type 1 = Analogue input 3 = Totaliser 2 = Maths 4 = Counter	Enum	Read only	06D3 (1747)	1
Ch11 Decimal places	Number of decimal places (0 to 9) (used by all scaled parameters except where stated)	Uint16	Read only	06D4 (1748)	1
Ch11 Colour	Channel colour (0 to 55) (See Annex B for RGB definitions)	Enum	Read only	06D5 (1749)	1
Ch11 Units	Units string (up to five characters)	String_5	Read only	06D6 (1750)	3
Spare				06D9 (1753)	2
Ch11 Open string	Open Digital Input string (up to eight characters)	String_8	Read only	06DB (1755)	4
Spare				06DF (1759)	4
Ch11 Close string	Closed Digital Input string (up to eight characters)	String_8	Read only	06E3 (1763)	4
Spare				06E7 (1767)	4
Ch11 Descriptor	Channel descriptor (up to 20 characters)	String_20	Read only	06EB (1771)	10
Spare				06F5 (1781)	10
Ch11 No of alarms	Number of alarms on this channel (0 to 2)	Uint16	Read only	06FF (1791)	1
Ch11 PV format	0 = Numeric 1 = Digital strings	Enum	Read only	0700 (1792)	1
Spare				0701 (1793)	60
Ch11 Alarm 1 enable	Alarm 1 enable 0 = Off 2 = Latched 1 = Unlatched 3 = Trigger	Enum	Read only	073D (1853)	1
Ch11 Alarm 1 type	Alarm 1 type 0 = Absolute low 1 = Absolute high 2 = Deviation in 3 = Deviation out 4 = Rate of change rise 5 = Rate of change fall	Enum	Read only	073E (1854)	1
Ch11 Alarm 1 setpoint	Trigger setpoint	Scaled	Read/Write	073F (1855)	1
Spare				0740 (1856)	10
Ch11 Alarm 2 enable	Alarm 2 enable (As alarm 1 enable, above)	Enum	Read only	074A (1866)	1
Ch11 Alarm 2 type	Alarm 2 type (As alarm 1 type, above)	Enum	Read only	074B (1867)	1
Ch11 Alarm 2 setpoint	Trigger setpoint	Scaled	Read/Write	074C (1868)	1
Spare				074D (1869)	10
Ch11 Alarm 3 enable	Alarm 3 enable (As alarm 1 enable above)	Enum	Read only	0757(1879)	1
Ch11 Alarm 3 type	Alarm 3 type (As alarm 1 type above)	Enum	Read only	0758 (1880)	1
Ch11 Alarm 3 setpoint	Trigger setpoint	Scaled	Read/Write	0759 (1881)	1
Spare				075A (1882)	10
Ch11 Alarm 4 enable	Alarm 4 enable (As alarm 1 enable above)	Enum	Read only	0764 (1892)	1
Ch11 Alarm 4 type	Alarm 4 type (As alarm 1 type above)	Enum	Read only	0765 (1893)	1
Ch11 Alarm 4 setpoint	Trigger setpoint	Scaled	Read/Write	0766 (1894)	1
Spare				0767 (1895)	10

Notes:

1. Alarms 3 and 4 are available only for instruments fitted with 32MB DRAM.
2. For maths, totalisers and counters, see the relevant option description.

2.4.2 CHANNEL CONFIGURATION DATA (Cont.)

CHANNEL 12

Parameter Name	Description	Type	Access	Start Addr. Hex (Dec)	Register Length
Ch12 Span high	Upper span value (display full scale)	Scaled	Read only	0771 (1905)	1
Ch12 Span low	Lower span value (display 'zero')	Scaled	Read only	0772 (1906)	1
Ch12 Zone high	Zone high value (two decimal places)	Scaled	Read only	0773 (1907)	1
Ch12 Zone low	Zone low value (two decimal places)	Scaled	Read only	0774 (1908)	1
Ch12 PV type	Input type 1 = Analogue input 3 = Totaliser 2 = Maths 4 = Counter	Enum	Read only	0775 (1909)	1
Ch12 Decimal places	Number of decimal places (0 to 9) (used by all scaled parameters except where stated)	UInt16	Read only	0776 (1910)	1
Ch12 Colour	Channel colour (0 to 55) (See Annex B for RGB definitions)	Enum	Read only	0777 (1911)	1
Ch12 Units	Units string (up to five characters)	String_5	Read only	0778 (1912)	3
Spare				077B (1915)	2
Ch12 Open string	Open Digital Input string (up to eight characters)	String_8	Read only	077D (1917)	4
Spare				0781 (1921)	4
Ch12 Close string	Closed Digital Input string (up to eight characters)	String_8	Read only	0785 (1925)	4
Spare				0789 (1929)	4
Ch12 Descriptor	Channel descriptor (up to 20 characters)	String_20	Read only	078D (1933)	10
Spare				0797 (1943)	10
Ch12 No of alarms	Number of alarms on this channel (0 to 2)	UInt16	Read only	07A1 (1953)	1
Ch12 PV format	0 = Numeric 1 = Digital strings	Enum	Read only	07A2 (1954)	1
Spare				07A3 (1955)	60
Ch12 Alarm 1 enable	Alarm 1 enable 0 = Off 2 = Latched 1 = Unlatched 3 = Trigger	Enum	Read only	07DF (2015)	1
Ch12 Alarm 1 type	Alarm 1 type 0 = Absolute low 1 = Absolute high 2 = Deviation in 3 = Deviation out 4 = Rate of change rise 5 = Rate of change fall	Enum	Read only	07E0 (2016)	1
Ch12 Alarm 1 setpoint	Trigger setpoint	Scaled	Read/Write	07E1 (2017)	1
Spare				07E2 (2018)	10
Ch12 Alarm 2 enable	Alarm 2 enable (As alarm 1 enable, above)	Enum	Read only	07EC (2028)	1
Ch12 Alarm 2 type	Alarm 2 type (As alarm 1 type, above)	Enum	Read only	07ED (2029)	1
Ch12 Alarm 2 setpoint	Trigger setpoint	Scaled	Read/Write	07EE (2030)	1
Spare				07EF (2031)	10
Ch12 Alarm 3 enable	Alarm 3 enable (As alarm 1 enable above)	Enum	Read only	07F9 (2041)	1
Ch12 Alarm 3 type	Alarm 3 type (As alarm 1 type above)	Enum	Read only	07FA (2042)	1
Ch12 Alarm 3 setpoint	Trigger setpoint	Scaled	Read/Write	07FB (2043)	1
Spare				07FC (2044)	10
Ch12 Alarm 4 enable	Alarm 4 enable (As alarm 1 enable above)	Enum	Read only	0806 (2054)	1
Ch12 Alarm 4 type	Alarm 4 type (As alarm 1 type above)	Enum	Read only	0807 (2055)	1
Ch12 Alarm 4 setpoint	Trigger setpoint	Scaled	Read/Write	0808 (2056)	1
Spare				0809 (2057)	10

Notes:

- Alarms 3 and 4 are available only for instruments fitted with 32MB DRAM.
- For maths, totalisers and counters, see the relevant option description.

2.4.3 Channel Run-Time data

These tables show addresses for channel input values for channels 1 to 12 inclusive.
 Generally: channel N address = channel 1 address + 3(N-1) (decimal)

CHANNEL 1

Parameter Name	Description	Type	Access	Start Addr. Hex (Dec)	Register Length
Ch1 value	Current process value (PV)	Scaled	See note	A1D9 (41433)	1
Ch1 status	Channel status	Enum	Read only	A1DA (41434)	1
Ch1 Alarms	0 = Good PV 5 = Ranging error 1 = Channel off 6 = Overflow 2 = Over range 7 = Bad PV 3 = Under range 8 = No data 4 = Hardware error	Uint16	-	A1DB (41435)	1
	Alarm information		Read only		
	Bit 0: 0 = Alarm 1 inactive; 1 = Alarm 1 active		Read only		
	Bit 1: 0 = No alarm 1 Ack. required; 1 = Ack. required		Read/Write		
	Bit 2: 1 = Acknowledge alarm 1		Read only		
	Bit 3: Spare		Read only		
	Bit 4: 0 = Alarm 2 inactive; 1 = Alarm 2 active		Read only		
	Bit 5: 0 = No Alarm 2 Ack. required; 1 = Ack. required		Read/Write		
	Bit 6: 1 = Acknowledge alarm 2		Read only		
	Bit 7: Spare		Read only		
	Bit 8: 0 = Alarm 3 inactive; 1 = Alarm 3 active		Read only		
	Bit 9: 0 = No alarm 3 Ack. required; 1 = Ack. required		Read/Write		
	Bit 10: 1 = Acknowledge alarm 3		Read only		
	Bit 11: Spare		Read only		
	Bit 12: 0 = Alarm 4 inactive; 1 = Alarm 4 active		Read only		
Bit 13: 0 = No Alarm 4 Ack. required; 1 = Ack. required	Read/Write				
Bit 14: 1 = Acknowledge alarm 4	Read only				
Bit 15: Spare	Read/Write				

CHANNEL 2

Parameter Name	Description	Type	Access	Start Addr. Hex (Dec)	Register Length
Ch2 value	Current process value (PV)	Scaled	See note	A1DC (41436)	1
Ch2 status	Channel status	Enum	Read only	A1DD (41437)	1
Ch2 Alarms	0 = Good PV 5 = Ranging error 1 = Channel off 6 = Overflow 2 = Over range 7 = Bad PV 3 = Under range 8 = No data 4 = Hardware error	Uint16	-	A1DE (41438)	1
	Alarm information		Read only		
	Bit 0: 0 = Alarm 1 inactive; 1 = Alarm 1 active		Read only		
	Bit 1: 0 = No alarm 1 Ack. required; 1 = Ack. required		Read/Write		
	Bit 2: 1 = Acknowledge alarm 1		Read only		
	Bit 3: Spare		Read only		
	Bit 4: 0 = Alarm 2 inactive; 1 = Alarm 2 active		Read only		
	Bit 5: 0 = No Alarm 2 Ack. required; 1 = Ack. required		Read/Write		
	Bit 6: 1 = Acknowledge alarm 2		Read only		
	Bit 7: Spare		Read only		
	Bit 8: 0 = Alarm 3 inactive; 1 = Alarm 3 active		Read only		
	Bit 9: 0 = No alarm 3 Ack. required; 1 = Ack. required		Read/Write		
	Bit 10: 1 = Acknowledge alarm 3		Read only		
	Bit 11: Spare		Read only		
	Bit 12: 0 = Alarm 4 inactive; 1 = Alarm 4 active		Read only		
Bit 13: 0 = No Alarm 4 Ack. required; 1 = Ack. required	Read/Write				
Bit 14: 1 = Acknowledge alarm 4	Read only				
Bit 15: Spare	Read/Write				

Notes

1. For measuring channels, access is read only; for derived channels, access is read/write
2. Alarms 3 and 4 are available only for instruments fitted with 32MB DRAM

2.4.3 CHANNEL RUN TIME DATA (Cont.)

CHANNEL 3

Parameter Name	Description	Type	Access	Start Addr. Hex (Dec)	Register Length
Ch3 value	Current process value (PV)	Scaled	See note	A1DF (41439)	1
Ch3 status	Channel status 0 = Good PV 5 = Ranging error 1 = Channel off 6 = Overflow 2 = Over range 7 = Bad PV 3 = Under range 8 = No data 4 = Hardware error	Enum	Read only	A1E0 (41440)	1
Ch3 Alarms	Alarm information Bit 0: 0 = Alarm 1 inactive; 1 = Alarm 1 active Bit 1: 0 = No alarm 1 Ack. required; 1 = Ack. required Bit 2: 1 = Acknowledge alarm 1 Bit 3: Spare Bit 4: 0 = Alarm 2 inactive; 1 = Alarm 2 active Bit 5: 0 = No Alarm 2 Ack. required; 1 = Ack. required Bit 6: 1 = Acknowledge alarm 2 Bit 7: Spare Bit 8: 0 = Alarm 3 inactive; 1 = Alarm 3 active Bit 9: 0 = No alarm 3 Ack. required; 1 = Ack. required Bit 10: 1 = Acknowledge alarm 3 Bit 11: Spare Bit 12: 0 = Alarm 4 inactive; 1 = Alarm 4 active Bit 13: 0 = No Alarm 4 Ack. required; 1 = Ack. required Bit 14: 1 = Acknowledge alarm 4 Bit 15: Spare	Uint16	- Read only Read only Read/Write Read only Read only Read/Write Read only Read only Read/Write Read only Read only Read/Write	A1E1 (41441)	1

CHANNEL 4

Parameter Name	Description	Type	Access	Start Addr. Hex (Dec)	Register Length
Ch4 value	Current process value (PV)	Scaled	See note	A1E2 (41442)	1
Ch4 status	Channel status 0 = Good PV 5 = Ranging error 1 = Channel off 6 = Overflow 2 = Over range 7 = Bad PV 3 = Under range 8 = No data 4 = Hardware error	Enum	Read only	A1E3 (41443)	1
Ch4 Alarms	Alarm information Bit 0: 0 = Alarm 1 inactive; 1 = Alarm 1 active Bit 1: 0 = No alarm 1 Ack. required; 1 = Ack. required Bit 2: 1 = Acknowledge alarm 1 Bit 3: Spare Bit 4: 0 = Alarm 2 inactive; 1 = Alarm 2 active Bit 5: 0 = No Alarm 2 Ack. required; 1 = Ack. required Bit 6: 1 = Acknowledge alarm 2 Bit 7: Spare Bit 8: 0 = Alarm 3 inactive; 1 = Alarm 3 active Bit 9: 0 = No alarm 3 Ack. required; 1 = Ack. required Bit 10: 1 = Acknowledge alarm 3 Bit 11: Spare Bit 12: 0 = Alarm 4 inactive; 1 = Alarm 4 active Bit 13: 0 = No Alarm 4 Ack. required; 1 = Ack. required Bit 14: 1 = Acknowledge alarm 4 Bit 15: Spare	Uint16	- Read only Read only Read/Write Read only Read only Read/Write Read only Read only Read/Write	A1E4 (41444)	1

Notes

1. For measuring channels, access is read only; for derived channels, access is read/write
2. Alarms 3 and 4 are available only for instruments fitted with 32MB DRAM

2.4.3 CHANNEL RUN TIME DATA (Cont.)

CHANNEL 5

Parameter Name	Description	Type	Access	Start Addr. Hex (Dec)	Register Length
Ch5 value	Current process value (PV)	Scaled	See note	A1E5 (41445)	1
Ch5 status	Channel status 0 = Good PV 5 = Ranging error 1 = Channel off 6 = Overflow 2 = Over range 7 = Bad PV 3 = Under range 8 = No data 4 = Hardware error	Enum	Read only	A1E6 (41446)	1
Ch5 Alarms	Alarm information Bit 0: 0 = Alarm 1 inactive; 1 = Alarm 1 active Bit 1: 0 = No alarm 1 Ack. required; 1 = Ack. required Bit 2: 1 = Acknowledge alarm 1 Bit 3: Spare Bit 4: 0 = Alarm 2 inactive; 1 = Alarm 2 active Bit 5: 0 = No Alarm 2 Ack. required; 1 = Ack. required Bit 6: 1 = Acknowledge alarm 2 Bit 7: Spare Bit 8: 0 = Alarm 3 inactive; 1 = Alarm 3 active Bit 9: 0 = No alarm 3 Ack. required; 1 = Ack. required Bit 10: 1 = Acknowledge alarm 3 Bit 11: Spare Bit 12: 0 = Alarm 4 inactive; 1 = Alarm 4 active Bit 13: 0 = No Alarm 4 Ack. required; 1 = Ack. required Bit 14: 1 = Acknowledge alarm 4 Bit 15: Spare	Uint16	- Read only Read only Read/Write Read only Read only Read/Write Read only Read only Read/Write Read only Read only Read/Write	A1E7 (41447)	1

CHANNEL 6

Parameter Name	Description	Type	Access	Start Addr. Hex (Dec)	Register Length
Ch6 value	Current process value (PV)	Scaled	See note	A1E8 (41448)	1
Ch6 status	Channel status 0 = Good PV 5 = Ranging error 1 = Channel off 6 = Overflow 2 = Over range 7 = Bad PV 3 = Under range 8 = No data 4 = Hardware error	Enum	Read only	A1E9 (41449)	1
Ch6 Alarms	Alarm information Bit 0: 0 = Alarm 1 inactive; 1 = Alarm 1 active Bit 1: 0 = No alarm 1 Ack. required; 1 = Ack. required Bit 2: 1 = Acknowledge alarm 1 Bit 3: Spare Bit 4: 0 = Alarm 2 inactive; 1 = Alarm 2 active Bit 5: 0 = No Alarm 2 Ack. required; 1 = Ack. required Bit 6: 1 = Acknowledge alarm 2 Bit 7: Spare Bit 8: 0 = Alarm 3 inactive; 1 = Alarm 3 active Bit 9: 0 = No alarm 3 Ack. required; 1 = Ack. required Bit 10: 1 = Acknowledge alarm 3 Bit 11: Spare Bit 12: 0 = Alarm 4 inactive; 1 = Alarm 4 active Bit 13: 0 = No Alarm 4 Ack. required; 1 = Ack. required Bit 14: 1 = Acknowledge alarm 4 Bit 15: Spare	Uint16	- Read only Read only Read/Write Read only Read only Read/Write Read only Read only Read/Write	A1EA (41450)	1

Notes

1. For measuring channels, access is read only; for derived channels, access is read/write
2. Alarms 3 and 4 are available only for instruments fitted with 32MB DRAM

2.4.3 CHANNEL RUN TIME DATA (Cont.)

CHANNEL 7

Parameter Name	Description	Type	Access	Start Addr. Hex (Dec)	Register Length
Ch7 value	Current process value (PV)	Scaled	See note	A1EB (41451)	1
Ch7 status	Channel status 0 = Good PV 5 = Ranging error 1 = Channel off 6 = Overflow 2 = Over range 7 = Bad PV 3 = Under range 8 = No data 4 = Hardware error	Enum	Read only	A1EC (41452)	1
Ch7 Alarms	Alarm information Bit 0: 0 = Alarm 1 inactive; 1 = Alarm 1 active Bit 1: 0 = No alarm 1 Ack. required; 1 = Ack. required Bit 2: 1 = Acknowledge alarm 1 Bit 3: Spare Bit 4: 0 = Alarm 2 inactive; 1 = Alarm 2 active Bit 5: 0 = No Alarm 2 Ack. required; 1 = Ack. required Bit 6: 1 = Acknowledge alarm 2 Bit 7: Spare Bit 8: 0 = Alarm 3 inactive; 1 = Alarm 3 active Bit 9: 0 = No alarm 3 Ack. required; 1 = Ack. required Bit 10: 1 = Acknowledge alarm 3 Bit 11: Spare Bit 12: 0 = Alarm 4 inactive; 1 = Alarm 4 active Bit 13: 0 = No Alarm 4 Ack. required; 1 = Ack. required Bit 14: 1 = Acknowledge alarm 4 Bit 15: Spare	Uint16	- Read only Read only Read/Write Read only Read only Read/Write Read only Read only Read/Write Read only Read only Read/Write	A1ED (41453)	1

CHANNEL 8

Parameter Name	Description	Type	Access	Start Addr. Hex (Dec)	Register Length
Ch8 value	Current process value (PV)	Scaled	See note	A1EE (41454)	1
Ch8 status	Channel status 0 = Good PV 5 = Ranging error 1 = Channel off 6 = Overflow 2 = Over range 7 = Bad PV 3 = Under range 8 = No data 4 = Hardware error	Enum	Read only	A1EF (41455)	1
Ch8 Alarms	Alarm information Bit 0: 0 = Alarm 1 inactive; 1 = Alarm 1 active Bit 1: 0 = No alarm 1 Ack. required; 1 = Ack. required Bit 2: 1 = Acknowledge alarm 1 Bit 3: Spare Bit 4: 0 = Alarm 2 inactive; 1 = Alarm 2 active Bit 5: 0 = No Alarm 2 Ack. required; 1 = Ack. required Bit 6: 1 = Acknowledge alarm 2 Bit 7: Spare Bit 8: 0 = Alarm 3 inactive; 1 = Alarm 3 active Bit 9: 0 = No alarm 3 Ack. required; 1 = Ack. required Bit 10: 1 = Acknowledge alarm 3 Bit 11: Spare Bit 12: 0 = Alarm 4 inactive; 1 = Alarm 4 active Bit 13: 0 = No Alarm 4 Ack. required; 1 = Ack. required Bit 14: 1 = Acknowledge alarm 4 Bit 15: Spare	Uint16	- Read only Read only Read/Write Read only Read only Read/Write Read only Read only Read/Write	A1F0 (41456)	1

Notes

1. For measuring channels, access is read only; for derived channels, access is read/write
2. Alarms 3 and 4 are available only for instruments fitted with 32MB DRAM

2.4.3 CHANNEL RUN TIME DATA (Cont.)

CHANNEL 9

Parameter Name	Description	Type	Access	Start Addr. Hex (Dec)	Register Length
Ch9 value	Current process value (PV)	Scaled	See note	A1F1 (41457)	1
Ch9 status	Channel status 0 = Good PV 5 = Ranging error 1 = Channel off 6 = Overflow 2 = Over range 7 = Bad PV 3 = Under range 8 = No data 4 = Hardware error	Enum	Read only	A1F2 (41458)	1
Ch9 Alarms	Alarm information Bit 0: 0 = Alarm 1 inactive; 1 = Alarm 1 active Bit 1: 0 = No alarm 1 Ack. required; 1 = Ack. required Bit 2: 1 = Acknowledge alarm 1 Bit 3: Spare Bit 4: 0 = Alarm 2 inactive; 1 = Alarm 2 active Bit 5: 0 = No Alarm 2 Ack. required; 1 = Ack. required Bit 6: 1 = Acknowledge alarm 2 Bit 7: Spare Bit 8: 0 = Alarm 3 inactive; 1 = Alarm 3 active Bit 9: 0 = No alarm 3 Ack. required; 1 = Ack. required Bit 10: 1 = Acknowledge alarm 3 Bit 11: Spare Bit 12: 0 = Alarm 4 inactive; 1 = Alarm 4 active Bit 13: 0 = No Alarm 4 Ack. required; 1 = Ack. required Bit 14: 1 = Acknowledge alarm 4 Bit 15: Spare	Uint16	- Read only Read only Read/Write Read only Read only Read/Write Read only Read only Read/Write Read only Read only Read/Write	A1F3 (41459)	1

CHANNEL 10

Parameter Name	Description	Type	Access	Start Addr. Hex (Dec)	Register Length
Ch10 value	Current process value (PV)	Scaled	See note	A1F4 (41460)	1
Ch10 status	Channel status 0 = Good PV 5 = Ranging error 1 = Channel off 6 = Overflow 2 = Over range 7 = Bad PV 3 = Under range 8 = No data 4 = Hardware error	Enum	Read only	A1F5 (41461)	1
Ch10 Alarms	Alarm information Bit 0: 0 = Alarm 1 inactive; 1 = Alarm 1 active Bit 1: 0 = No alarm 1 Ack. required; 1 = Ack. required Bit 2: 1 = Acknowledge alarm 1 Bit 3: Spare Bit 4: 0 = Alarm 2 inactive; 1 = Alarm 2 active Bit 5: 0 = No Alarm 2 Ack. required; 1 = Ack. required Bit 6: 1 = Acknowledge alarm 2 Bit 7: Spare Bit 8: 0 = Alarm 3 inactive; 1 = Alarm 3 active Bit 9: 0 = No alarm 3 Ack. required; 1 = Ack. required Bit 10: 1 = Acknowledge alarm 3 Bit 11: Spare Bit 12: 0 = Alarm 4 inactive; 1 = Alarm 4 active Bit 13: 0 = No Alarm 4 Ack. required; 1 = Ack. required Bit 14: 1 = Acknowledge alarm 4 Bit 15: Spare	Uint16	- Read only Read only Read/Write Read only Read only Read/Write Read only Read only Read/Write	A1F6 (41462)	1

Notes

1. For measuring channels, access is read only; for derived channels, access is read/write
2. Alarms 3 and 4 are available only for instruments fitted with 32MB DRAM

2.4.3 CHANNEL RUN TIME DATA (Cont.)

CHANNEL 11

Parameter Name	Description	Type	Access	Start Addr. Hex (Dec)	Register Length
Ch11 value	Current process value (PV)	Scaled	See note	A1F7 (41463)	1
Ch11 status	Channel status 0 = Good PV 5 = Ranging error 1 = Channel off 6 = Overflow 2 = Over range 7 = Bad PV 3 = Under range 8 = No data 4 = Hardware error	Enum	Read only	A1F8 (41464)	1
Ch11 Alarms	Alarm information Bit 0: 0 = Alarm 1 inactive; 1 = Alarm 1 active Bit 1: 0 = No alarm 1 Ack. required; 1 = Ack. required Bit 2: 1 = Acknowledge alarm 1 Bit 3: Spare Bit 4: 0 = Alarm 2 inactive; 1 = Alarm 2 active Bit 5: 0 = No Alarm 2 Ack. required; 1 = Ack. required Bit 6: 1 = Acknowledge alarm 2 Bit 7: Spare Bit 8: 0 = Alarm 3 inactive; 1 = Alarm 3 active Bit 9: 0 = No alarm 3 Ack. required; 1 = Ack. required Bit 10: 1 = Acknowledge alarm 3 Bit 11: Spare Bit 12: 0 = Alarm 4 inactive; 1 = Alarm 4 active Bit 13: 0 = No Alarm 4 Ack. required; 1 = Ack. required Bit 14: 1 = Acknowledge alarm 4 Bit 15: Spare	Uint16	- Read only Read only Read/Write Read only Read only Read/Write Read only Read only Read/Write Read only Read only Read/Write	A1F9 (41465)	1

CHANNEL 12

Parameter Name	Description	Type	Access	Start Addr. Hex (Dec)	Register Length
Ch12 value	Current process value (PV)	Scaled	See note	A1FA (41466)	1
Ch12 status	Channel status 0 = Good PV 5 = Ranging error 1 = Channel off 6 = Overflow 2 = Over range 7 = Bad PV 3 = Under range 8 = No data 4 = Hardware error	Enum	Read only	A1FB (41467)	1
Ch12 Alarms	Alarm information Bit 0: 0 = Alarm 1 inactive; 1 = Alarm 1 active Bit 1: 0 = No alarm 1 Ack. required; 1 = Ack. required Bit 2: 1 = Acknowledge alarm 1 Bit 3: Spare Bit 4: 0 = Alarm 2 inactive; 1 = Alarm 2 active Bit 5: 0 = No Alarm 2 Ack. required; 1 = Ack. required Bit 6: 1 = Acknowledge alarm 2 Bit 7: Spare Bit 8: 0 = Alarm 3 inactive; 1 = Alarm 3 active Bit 9: 0 = No alarm 3 Ack. required; 1 = Ack. required Bit 10: 1 = Acknowledge alarm 3 Bit 11: Spare Bit 12: 0 = Alarm 4 inactive; 1 = Alarm 4 active Bit 13: 0 = No Alarm 4 Ack. required; 1 = Ack. required Bit 14: 1 = Acknowledge alarm 4 Bit 15: Spare	Uint16	- Read only Read only Read/Write Read only Read only Read/Write Read only Read only Read/Write	A1FC (41468)	1

Notes

1. For measuring channels, access is read only; for derived channels, access is read/write
2. Alarms 3 and 4 are available only for instruments fitted with 32MB DRAM

2.4.4 Group data

Generally: Parameter address for group N = Parameter address for group 1 + 629(N-1) (decimal)

GROUP 1

Parameter Name	Description	Type	Access	Start Addr. Hex (Dec)	Register Length
Grp1 Trend type	Trend enhancements 0 = Interpolation enabled 1 = Adaptive recording enabled	Enum	Read only	A4D6 (42198)	1
Grp1 Trend rate	Trend update rate in milliseconds	UInt32	Read only	A4D7 (42199)	2
Grp1 Archive rate	Archive (to flash) rate in milliseconds	UInt 32	Read only	A4D9 (42201)	2
Grp1 Descriptor	Group descriptor (20 characters max.)	String_20	Read only	A4DB (42203)	10
Spare				A4E5 (42213)	10
Grp1 Channels in group	16 Registers holding the group contents, as follows: Register 1 Bit 0: 0 = Point 1 not in group; 1 = Point 1 is in group Bit 1: 0 = Point 2 not in group; 1 = Point 2 is in group Bit 2: 0 = Point 3 not in group; 1 = Point 3 is in group Etc. Bit 15: 0 = Point 16 not in group; 1 = Point 16 is in group Register 2 - as register 1, but for points 17 to 32 Register 3 - as register 1, but for points 33 to 48 Register 4 - as register 1, but for points 49 to 64 Register 5 - as register 1, but for points 65 to 80 Register 6 - as register 1, but for points 81 to 96 Register 7 - as register 1, but for points 97 to 112 Register 8 - as register 1, but for points 113 to 128 Register 9 - as register 1, but for points 129 to 144 Register 10 - as register 1, but for points 145 to 160 Register 11 - as register 1, but for points 161 to 176 Register 12 - as register 1, but for points 177 to 192 Register 13 - as register 1, but for points 193 to 208 Register 14 - as register 1, but for points 209 to 224 Register 15 - as register 1, but for points 225 to 240 Register 16 - as register 1, but for points 241 to 256	UInt16	Read only	A4EF (42223)	(16) 1
See table 2.3 for point types	Register 2 - as register 1, but for points 17 to 32	UInt16	Read only	A4F0 (42224)	1
	Register 3 - as register 1, but for points 33 to 48	UInt16	Read only	A4F1 (42225)	1
	Register 4 - as register 1, but for points 49 to 64	UInt16	Read only	A4F2 (42226)	1
	Register 5 - as register 1, but for points 65 to 80	UInt16	Read only	A4F3 (42227)	1
	Register 6 - as register 1, but for points 81 to 96	UInt16	Read only	A4F4 (42228)	1
	Register 7 - as register 1, but for points 97 to 112	UInt16	Read only	A4F5 (42229)	1
	Register 8 - as register 1, but for points 113 to 128	UInt16	Read only	A4F6 (42230)	1
	Register 9 - as register 1, but for points 129 to 144	UInt16	Read only	A4F7 (42231)	1
	Register 10 - as register 1, but for points 145 to 160	UInt16	Read only	A4F8 (42232)	1
	Register 11 - as register 1, but for points 161 to 176	UInt16	Read only	A4F9 (42233)	1
	Register 12 - as register 1, but for points 177 to 192	UInt16	Read only	A4FA (42234)	1
	Register 13 - as register 1, but for points 193 to 208	UInt16	Read only	A4FB (42235)	1
	Register 14 - as register 1, but for points 209 to 224	UInt16	Read only	A4FC (42236)	1
	Register 15 - as register 1, but for points 225 to 240	UInt16	Read only	A4FD (42237)	1
	Register 16 - as register 1, but for points 241 to 256	UInt16	Read only	A4FE (42238)	1
	Grp1 Text length	Identifies the length of a text message to be read	UInt16	Read/Write	A4FF (42239)
Grp1 Text time stamp	Time stamp of the text message to be read (UTC format)	Double	Read only	A500 (42240)	4
Grp1 Read text	Read text string from instrument display	String_60	Read only	A504 (42244)	30
Reserved				A522 (42274)	30
Grp1 Write text	Write a text string (30 characters max) to instrument display	String_60	Write only	A540 (42304)	30
Reserved				A55E (42334)	30
Grp1 Batch start	Boolean Flag. Value 0001 starts new batch	Boolean	Write only	A57C (42364)	1
Grp1 Batch stop	Boolean Flag. Value 0001 stops current batch	Boolean	Write only	A57D (42365)	1
Grp1 Batch running	Batch status flag: 1 = Running; 0 = Not running	Boolean	Read only	A57E (42366)	1
Grp1 Text field 1	Batch field 1 text string (max. 60 characters)	String_60	Read/Write	A57F (42367)	30
Reserved				A59D (42397)	30
Grp1 Text field 2	Batch field 2 text string (max. 60 characters)	String_60	Read/Write	A5BB (42427)	30
Reserved				A5D9 (42457)	30
Grp1 Text field 3	Batch field 3 text string (max. 60 characters)	String_60	Read/Write	A5F7 (42487)	30
Reserved				A615 (42517)	30
Grp1 Text field 4	Batch field 4 text string (max. 60 characters)	String_60	Read/Write	A633 (42547)	30
Reserved				A651 (42577)	30
Grp1 Text field 5	Batch field 5 text string (max. 60 characters)	String_60	Read/Write	A66F (42607)	30
Reserved				A68D (42637)	30
Grp1 Text field 6	Batch field 6 text string (max. 60 characters)	String_60	Read/Write	A6AB (42667)	30
Reserved				A6C9 (42697)	30
Spare				A6E7 (42727)	100

2.4.4 GROUP DATA (Cont.)

GROUP 2

Parameter Name	Description	Type	Access	Start Addr. Hex (Dec)	Register Length
Grp2 Trend type	Trend enhancements 0 = Interpolation enabled 1 = Adaptive recording enabled	Enum	Read only	A74B (42827)	1
Grp2 Trend rate	Trend update rate in milliseconds	UInt32	Read only	A74C (42828)	2
Grp2 Archive rate	Archive (to flash) rate in milliseconds	UInt 32	Read only	A74E (42830)	2
Grp2 Descriptor	Group descriptor (20 characters max.)	String_20	Read only	A750 (42832)	10
Spare				A75A (42842)	10
Grp2 Channels in group	16 Registers holding the group contents, as follows: Register 1 Bit 0: 0 = Point 1 not in group; 1 = Point 1 is in group Bit 1: 0 = Point 2 not in group; 1 = Point 2 is in group Bit 2: 0 = Point 3 not in group; 1 = Point 3 is in group Etc. Bit 15: 0 = Point 16 not in group; 1 = Point 16 is in group Register 2 - as register 1, but for points 17 to 32 Register 3 - as register 1, but for points 33 to 48 Register 4 - as register 1, but for points 49 to 64 Register 5 - as register 1, but for points 65 to 80 Register 6 - as register 1, but for points 81 to 96 Register 7 - as register 1, but for points 97 to 112 Register 8 - as register 1, but for points 113 to 128 Register 9 - as register 1, but for points 129 to 144 Register 10 - as register 1, but for points 145 to 160 Register 11 - as register 1, but for points 161 to 176 Register 12 - as register 1, but for points 177 to 192 Register 13 - as register 1, but for points 193 to 208 Register 14 - as register 1, but for points 209 to 224 Register 15 - as register 1, but for points 225 to 240 Register 16 - as register 1, but for points 241 to 256	UInt16	Read only	A764 (42852)	(16) 1
See table 2.3 for point types	Register 2 - as register 1, but for points 17 to 32	UInt16	Read only	A765 (42853)	1
	Register 3 - as register 1, but for points 33 to 48	UInt16	Read only	A766 (42854)	1
	Register 4 - as register 1, but for points 49 to 64	UInt16	Read only	A767 (42855)	1
	Register 5 - as register 1, but for points 65 to 80	UInt16	Read only	A768 (42856)	1
	Register 6 - as register 1, but for points 81 to 96	UInt16	Read only	A769 (42857)	1
	Register 7 - as register 1, but for points 97 to 112	UInt16	Read only	A76A(42858)	1
	Register 8 - as register 1, but for points 113 to 128	UInt16	Read only	A76B (42859)	1
	Register 9 - as register 1, but for points 129 to 144	UInt16	Read only	A76C (42860)	1
	Register 10 - as register 1, but for points 145 to 160	UInt16	Read only	A76D (42861)	1
	Register 11 - as register 1, but for points 161 to 176	UInt16	Read only	A76E (42862)	1
	Register 12 - as register 1, but for points 177 to 192	UInt16	Read only	A76F (42863)	1
	Register 13 - as register 1, but for points 193 to 208	UInt16	Read only	A770 (42864)	1
	Register 14 - as register 1, but for points 209 to 224	UInt16	Read only	A771 (42865)	1
	Register 15 - as register 1, but for points 225 to 240	UInt16	Read only	A772 (42866)	1
	Register 16 - as register 1, but for points 241 to 256	UInt16	Read only	A773 (42867)	1
	Grp2 Text length	Identifies the length of a text message to be read	UInt16	Read/Write	A774 (42868)
Grp2 Text time stamp	Time stamp of the text message to be read (UTC format)	Double	Read only	A775 (42869)	4
Grp2 Read text	Read text string from instrument display	String_60	Read only	A779 (42873)	30
Reserved				A797 (42903)	30
Grp2 Write text	Write a text string (30 characters max) to instrument display	String_60	Write only	A7B5 (42933)	30
Reserved				A7D3 (42963)	30
Grp2 Batch start	Boolean Flag. Value 0001 starts new batch	Boolean	Write only	A7F1 (42993)	1
Grp2 Batch stop	Boolean Flag. Value 0001 stops current batch	Boolean	Write only	A7F2 (42994)	1
Grp2 Batch running	Batch status flag: 1 = Running; 0 = Not running	Boolean	Read only	A7F3 (42995)	1
Grp2 Text field 1	Batch field 1 text string (max. 60 characters)	String_60	Read/Write	A7F4 (42996)	30
Reserved				A812 (43026)	30
Grp2 Text field 2	Batch field 2 text string (max. 60 characters)	String_60	Read/Write	A830 (43056)	30
Reserved				A84E (43086)	30
Grp2 Text field 3	Batch field 3 text string (max. 60 characters)	String_60	Read/Write	A86C (43116)	30
Reserved				A88A (43146)	30
Grp2 Text field 4	Batch field 4 text string (max. 60 characters)	String_60	Read/Write	A8A8 (43176)	30
Reserved				A8C6 (43206)	30
Grp2 Text field 5	Batch field 5 text string (max. 60 characters)	String_60	Read/Write	A8E4 (43236)	30
Reserved				A902 (43266)	30
Grp2 Text field 6	Batch field 6 text string (max. 60 characters)	String_60	Read/Write	A920 (43296)	30
Reserved				A93E (43326)	30
Spare				A95C (43356)	100

2.4.4 GROUP DATA (Cont.)

GROUP 3

Parameter Name	Description	Type	Access	Start Addr. Hex (Dec)	Register Length
Grp3 Trend type	Trend enhancements 0 = Interpolation enabled 1 = Adaptive recording enabled	Enum	Read only	A9C0 (43456)	1
Grp3 Trend rate	Trend update rate in milliseconds	Uint32	Read only	A9C1 (43457)	2
Grp3 Archive rate	Archive (to flash) rate in milliseconds	Uint 32	Read only	A9C3 (43459)	2
Grp3 Descriptor	Group descriptor (20 characters max.)	String_20	Read only	A9C5 (43461)	10
Spare				A9CF (43471)	10
Grp3 Channels in group	16 Registers holding the group contents, as follows: Register 1 Bit 0: 0 = Point 1 not in group; 1 = Point 1 is in group Bit 1: 0 = Point 2 not in group; 1 = Point 2 is in group Bit 2: 0 = Point 3 not in group; 1 = Point 3 is in group Etc. Bit 15: 0 = Point 16 not in group; 1 = Point 16 is in group Register 2 - as register 1, but for points 17 to 32 Register 3 - as register 1, but for points 33 to 48 Register 4 - as register 1, but for points 49 to 64 Register 5 - as register 1, but for points 65 to 80 Register 6 - as register 1, but for points 81 to 96 Register 7 - as register 1, but for points 97 to 112 Register 8 - as register 1, but for points 113 to 128 Register 9 - as register 1, but for points 129 to 144 Register 10 - as register 1, but for points 145 to 160 Register 11 - as register 1, but for points 161 to 176 Register 12 - as register 1, but for points 177 to 192 Register 13 - as register 1, but for points 193 to 208 Register 14 - as register 1, but for points 209 to 224 Register 15 - as register 1, but for points 225 to 240 Register 16 - as register 1, but for points 241 to 256	Uint16	Read only	A9D9 (43481)	(16) 1
See table 2.3 for point types	Register 2 - as register 1, but for points 17 to 32	Uint16	Read only	A9DA (42482)	1
	Register 3 - as register 1, but for points 33 to 48	Uint16	Read only	A9DB (42483)	1
	Register 4 - as register 1, but for points 49 to 64	Uint16	Read only	A9DC (42484)	1
	Register 5 - as register 1, but for points 65 to 80	Uint16	Read only	A9DD (42485)	1
	Register 6 - as register 1, but for points 81 to 96	Uint16	Read only	A9DE (42486)	1
	Register 7 - as register 1, but for points 97 to 112	Uint16	Read only	A9DF (42487)	1
	Register 8 - as register 1, but for points 113 to 128	Uint16	Read only	A9E0 (42488)	1
	Register 9 - as register 1, but for points 129 to 144	Uint16	Read only	A9E1 (42489)	1
	Register 10 - as register 1, but for points 145 to 160	Uint16	Read only	A9E2 (42490)	1
	Register 11 - as register 1, but for points 161 to 176	Uint16	Read only	A9E3 (42491)	1
	Register 12 - as register 1, but for points 177 to 192	Uint16	Read only	A9E4 (42492)	1
	Register 13 - as register 1, but for points 193 to 208	Uint16	Read only	A9E5 (42493)	1
	Register 14 - as register 1, but for points 209 to 224	Uint16	Read only	A9E6 (42494)	1
	Register 15 - as register 1, but for points 225 to 240	Uint16	Read only	A9E7 (42495)	1
	Register 16 - as register 1, but for points 241 to 256	Uint16	Read only	A9E8 (43496)	1
	Grp3 Text length	Identifies the length of a text message to be read	Uint16	Read/Write	A9E9 (43497)
Grp3 Text time stamp	Time stamp of the text message to be read (UTC format)	Double	Read only	A9EA (43498)	4
Grp3 Read text	Read text string from instrument display	String_60	Read only	A9EE (43502)	30
Reserved				AA0C (43532)	30
Grp3 Write text	Write a text string (30 characters max) to instrument display	String_120	Write only	AA2A (43562)	60
Reserved				AA48 (43592)	30
Grp3 Batch start	Boolean Flag. Value 0001 starts new batch	Boolean	Write only	AA66 (43622)	1
Grp3 Batch stop	Boolean Flag. Value 0001 stops current batch	Boolean	Write only	AA67 (43623)	1
Grp3 Batch running	Batch status flag: 1 = Running; 0 = Not running	Boolean	Read only	AA68 (43624)	1
Grp3 Text field 1	Batch field 1 text string (max. 60 characters)	String_60	Read/Write	AA69 (43625)	30
Reserved				AA87 (43655)	30
Grp3 Text field 2	Batch field 2 text string (max. 60 characters)	String_60	Read/Write	AAA5 (43685)	30
Reserved				AAC3 (43715)	30
Grp3 Text field 3	Batch field 3 text string (max. 60 characters)	String_60	Read/Write	AAE1 (43745)	30
Reserved				A AFF (43775)	30
Grp3 Text field 4	Batch field 4 text string (max. 60 characters)	String_60	Read/Write	AB1D (43805)	30
Reserved				AB3B (43835)	30
Grp3 Text field 5	Batch field 5 text string (max. 60 characters)	String_60	Read/Write	AB59 (43865)	30
Reserved				AB77 (43895)	30
Grp3 Text field 6	Batch field 6 text string (max. 60 characters)	String_60	Read/Write	AB95 (43925)	30
Reserved				ABB3 (43955)	30
Spare				ABD1 (43985)	100

2.4.4 GROUP DATA (Cont.)

GROUP 4

Parameter Name	Description	Type	Access	Start Addr. Hex (Dec)	Register Length
Grp4 Trend type	Trend enhancements 0 = Interpolation enabled 1 = Adaptive recording enabled	Enum	Read only	AC35 (44085)	1
Grp4 Trend rate	Trend update rate in milliseconds	UInt32	Read only	AC36 (44086)	2
Grp4 Archive rate	Archive (to flash) rate in milliseconds	UInt 32	Read only	AC38 (44088)	2
Grp4 Descriptor	Group descriptor (20 characters max.)	String_20	Read only	AC3A (44090)	10
Spare				AC44 (44100)	10
Grp4 Channels in group	16 Registers holding the group contents, as follows: Register 1 Bit 0: 0 = Point 1 not in group; 1 = Point 1 is in group Bit 1: 0 = Point 2 not in group; 1 = Point 2 is in group Bit 2: 0 = Point 3 not in group; 1 = Point 3 is in group Etc. Bit 15: 0 = Point 16 not in group; 1 = Point 16 is in group Register 2 - as register 1, but for points 17 to 32 Register 3 - as register 1, but for points 33 to 48 Register 4 - as register 1, but for points 49 to 64 Register 5 - as register 1, but for points 65 to 80 Register 6 - as register 1, but for points 81 to 96 Register 7 - as register 1, but for points 97 to 112 Register 8 - as register 1, but for points 113 to 128 Register 9 - as register 1, but for points 129 to 144 Register 10 - as register 1, but for points 145 to 160 Register 11 - as register 1, but for points 161 to 176 Register 12 - as register 1, but for points 177 to 192 Register 13 - as register 1, but for points 193 to 208 Register 14 - as register 1, but for points 209 to 224 Register 15 - as register 1, but for points 225 to 240 Register 16 - as register 1, but for points 241 to 256	UInt16	Read only	AC4E (44110)	(16) 1
	See table 2.3 for point types				
Grp4 Text length	Identifies the length of a text message to be read	UInt16	Read/Write	AC5E (44126)	1
Grp4 Text time stamp	Time stamp of the text message to be read (UTC format)	Double	Read only	AC5F (44127)	4
Grp4 Read text	Read text string from instrument display	String_60	Read only	AC63 (44131)	30
Reserved				AC81 (44161)	30
Grp4 Write text	Write a text string (30 characters max) to instrument display	String_60	Write only	AC9F (44191)	30
Reserved				ACBD (44221)	30
Grp4 Batch start	Boolean Flag. Value 0001 starts new batch	Boolean	Write only	ACDB (44251)	1
Grp4 Batch stop	Boolean Flag. Value 0001 stops current batch	Boolean	Write only	ACDC (44252)	1
Grp4 Batch running	Batch status flag: 1 = Running; 0 = Not running	Boolean	Read only	ACDD (44253)	1
Grp4 Text field 1	Batch field 1 text string (max. 60 characters)	String_60	Read/Write	ACDE (44254)	30
Reserved				ACFC (44284)	30
Grp4 Text field 2	Batch field 2 text string (max. 60 characters)	String_60	Read/Write	AD1A (44314)	30
Reserved				AD38 (44344)	30
Grp4 Text field 3	Batch field 3 text string (max. 60 characters)	String_60	Read/Write	AD56 (44374)	30
Reserved				AD74 (44404)	30
Grp4 Text field 4	Batch field 4 text string (max. 60 characters)	String_60	Read/Write	AD92 (44434)	30
Reserved				ADB0 (44464)	30
Grp4 Text field 5	Batch field 5 text string (max. 60 characters)	String_60	Read/Write	ADCE (44494)	30
Reserved				ADEC (44524)	30
Grp4 Text field 6	Batch field 6 text string (max. 60 characters)	String_60	Read/Write	AE0A (44554)	30
Reserved				AE28 (44584)	30
Spare				AE46 (44614)	100

2.4.4 GROUP DATA (Cont.)

GROUP 5

Parameter Name	Description	Type	Access	Start Addr. Hex (Dec)	Register Length
Grp5 Trend type	Trend enhancements 0 = Interpolation enabled 1 = Adaptive recording enabled	Enum	Read only	AEAA (44714)	1
Grp5 Trend rate	Trend update rate in milliseconds	UInt32	Read only	AEAB (44715)	2
Grp5 Archive rate	Archive (to flash) rate in milliseconds	UInt 32	Read only	AEAD (44717)	2
Grp5 Descriptor	Group descriptor (20 characters max.)	String_20	Read only	AEAF (44719)	10
Spare				AEB9 (44729)	10
Grp5 Channels in group	16 Registers holding the group contents, as follows: Register 1 Bit 0: 0 = Point 1 not in group; 1 = Point 1 is in group Bit 1: 0 = Point 2 not in group; 1 = Point 2 is in group Bit 2: 0 = Point 3 not in group; 1 = Point 3 is in group Etc. Bit 15: 0 = Point 16 not in group; 1 = Point 16 is in group Register 2 - as register 1, but for points 17 to 32 Register 3 - as register 1, but for points 33 to 48 Register 4 - as register 1, but for points 49 to 64 Register 5 - as register 1, but for points 65 to 80 Register 6 - as register 1, but for points 81 to 96 Register 7 - as register 1, but for points 97 to 112 Register 8 - as register 1, but for points 113 to 128 Register 9 - as register 1, but for points 129 to 144 Register 10 - as register 1, but for points 145 to 160 Register 11 - as register 1, but for points 161 to 176 Register 12 - as register 1, but for points 177 to 192 Register 13 - as register 1, but for points 193 to 208 Register 14 - as register 1, but for points 209 to 224 Register 15 - as register 1, but for points 225 to 240 Register 16 - as register 1, but for points 241 to 256	UInt16	Read only	AEC3 (44739)	(16) 1
See table 2.3 for point types	Register 2 - as register 1, but for points 17 to 32	UInt16	Read only	AEC4 (44740)	1
	Register 3 - as register 1, but for points 33 to 48	UInt16	Read only	AEC5 (44741)	1
	Register 4 - as register 1, but for points 49 to 64	UInt16	Read only	AEC6 (44742)	1
	Register 5 - as register 1, but for points 65 to 80	UInt16	Read only	AEC7 (44743)	1
	Register 6 - as register 1, but for points 81 to 96	UInt16	Read only	AEC8 (44744)	1
	Register 7 - as register 1, but for points 97 to 112	UInt16	Read only	AEC9 (44745)	1
	Register 8 - as register 1, but for points 113 to 128	UInt16	Read only	AECA (44746)	1
	Register 9 - as register 1, but for points 129 to 144	UInt16	Read only	AECB (44747)	1
	Register 10 - as register 1, but for points 145 to 160	UInt16	Read only	AECC (44748)	1
	Register 11 - as register 1, but for points 161 to 176	UInt16	Read only	AECD (44749)	1
	Register 12 - as register 1, but for points 177 to 192	UInt16	Read only	AECE (44750)	1
	Register 13 - as register 1, but for points 193 to 208	UInt16	Read only	AECF (44751)	1
	Register 14 - as register 1, but for points 209 to 224	UInt16	Read only	AED0 (44752)	1
	Register 15 - as register 1, but for points 225 to 240	UInt16	Read only	AED1 (42253)	1
	Register 16 - as register 1, but for points 241 to 256	UInt16	Read only	AED2 (44754)	1
	Grp5 Text length	Identifies the length of a text message to be read	UInt16	Read/Write	AED3 (44755)
Grp5 Text time stamp	Time stamp of the text message to be read (UTC format)	Double	Read only	AED4 (44756)	4
Grp5 Read text	Read text string from instrument display	String_60	Read only	AED8 (44760)	30
Reserved				AEF6 (44790)	30
Grp5 Write text	Write a text string (30 characters max) to instrument display	String_60	Write only	AF14 (44820)	30
Reserved				AF32 (44850)	30
Grp5 Batch start	Boolean Flag. Value 0001 starts new batch	Boolean	Write only	AF50 (44880)	1
Grp5 Batch stop	Boolean Flag. Value 0001 stops current batch	Boolean	Write only	AF51 (44881)	1
Grp5 Batch running	Batch status flag: 1 = Running; 0 = Not running	Boolean	Read only	AF52 (44882)	1
Grp5 Text field 1	Batch field 1 text string (max. 60 characters)	String_60	Read/Write	AF53 (44883)	30
Reserved				AF71 (44913)	30
Grp5 Text field 2	Batch field 2 text string (max. 60 characters)	String_60	Read/Write	AF8F (44943)	30
Reserved				AFAD (44973)	30
Grp5 Text field 3	Batch field 3 text string (max. 60 characters)	String_60	Read/Write	AFCB (45003)	30
Reserved				AFE9 (45033)	30
Grp5 Text field 4	Batch field 4 text string (max. 60 characters)	String_60	Read/Write	B007 (45063)	30
Reserved				B025 (45093)	30
Grp5 Text field 5	Batch field 5 text string (max. 60 characters)	String_60	Read/Write	B043 (45123)	30
Reserved				B061 (45153)	30
Grp5 Text field 6	Batch field 6 text string (max. 60 characters)	String_60	Read/Write	B08F (45183)	30
Reserved				B09D (45213)	30
Spare				BOBB (45243)	100

2.4.4 GROUP DATA (Cont.)

GROUP 6

Parameter Name	Description	Type	Access	Start Addr. Hex (Dec)	Register Length
Grp6 Trend type	Trend enhancements 0 = Interpolation enabled 1 = Adaptive recording enabled	Enum	Read only	B11F (45343)	1
Grp6 Trend rate	Trend update rate in milliseconds	UInt32	Read only	B120 (45344)	2
Grp6 Archive rate	Archive (to flash) rate in milliseconds	UInt 32	Read only	B122 (45346)	2
Grp6 Descriptor	Group descriptor (20 characters max.)	String_20	Read only	B124 (45348)	10
Spare				B12E (45358)	10
Grp6 Channels in group	16 Registers holding the group contents, as follows: Register 1 Bit 0: 0 = Point 1 not in group; 1 = Point 1 is in group Bit 1: 0 = Point 2 not in group; 1 = Point 2 is in group Bit 2: 0 = Point 3 not in group; 1 = Point 3 is in group Etc. Bit 15: 0 = Point 16 not in group; 1 = Point 16 is in group Register 2 - as register 1, but for points 17 to 32 Register 3 - as register 1, but for points 33 to 48 Register 4 - as register 1, but for points 49 to 64 Register 5 - as register 1, but for points 65 to 80 Register 6 - as register 1, but for points 81 to 96 Register 7 - as register 1, but for points 97 to 112 Register 8 - as register 1, but for points 113 to 128 Register 9 - as register 1, but for points 129 to 144 Register 10 - as register 1, but for points 145 to 160 Register 11 - as register 1, but for points 161 to 176 Register 12 - as register 1, but for points 177 to 192 Register 13 - as register 1, but for points 193 to 208 Register 14 - as register 1, but for points 209 to 224 Register 15 - as register 1, but for points 225 to 240 Register 16 - as register 1, but for points 241 to 256	UInt16	Read only	B138 (45368)	(16) 1
See table 2.3 for point types	Register 2 - as register 1, but for points 17 to 32	UInt16	Read only	B139 (45369)	1
	Register 3 - as register 1, but for points 33 to 48	UInt16	Read only	B13A (45370)	1
	Register 4 - as register 1, but for points 49 to 64	UInt16	Read only	B13B (45371)	1
	Register 5 - as register 1, but for points 65 to 80	UInt16	Read only	B13C (45372)	1
	Register 6 - as register 1, but for points 81 to 96	UInt16	Read only	B13D (45373)	1
	Register 7 - as register 1, but for points 97 to 112	UInt16	Read only	B13E (45374)	1
	Register 8 - as register 1, but for points 113 to 128	UInt16	Read only	B13F (45375)	1
	Register 9 - as register 1, but for points 129 to 144	UInt16	Read only	B140 (45376)	1
	Register 10 - as register 1, but for points 145 to 160	UInt16	Read only	B141 (45377)	1
	Register 11 - as register 1, but for points 161 to 176	UInt16	Read only	B142 (45378)	1
	Register 12 - as register 1, but for points 177 to 192	UInt16	Read only	B143 (45379)	1
	Register 13 - as register 1, but for points 193 to 208	UInt16	Read only	B144 (45380)	1
	Register 14 - as register 1, but for points 209 to 224	UInt16	Read only	B145 (45381)	1
	Register 15 - as register 1, but for points 225 to 240	UInt16	Read only	B146 (45382)	1
	Register 16 - as register 1, but for points 241 to 256	UInt16	Read only	B147 (45383)	1
	Grp6 Text length	Identifies the length of a text message to be read	UInt16	Read/Write	B148 (45384)
Grp6 Text time stamp	Time stamp of the text message to be read (UTC format)	Double	Read only	B149 (45385)	4
Grp6 Read text	Read text string from instrument display	String_60	Read only	B14D (45389)	30
Reserved				B16B (45419)	30
Grp6 Write text	Write a text string (30 characters max) to instrument display	String_60	Write only	B189 (45449)	30
Reserved				B1A7 (45479)	30
Grp6 Batch start	Boolean Flag. Value 0001 starts new batch	Boolean	Write only	B1C5 (45509)	1
Grp6 Batch stop	Boolean Flag. Value 0001 stops current batch	Boolean	Write only	B1C6 (45510)	1
Grp6 Batch running	Batch status flag: 1 = Running; 0 = Not running	Boolean	Read only	B1C7 (45511)	1
Grp6 Text field 1	Batch field 1 text string (max. 60 characters)	String_60	Read/Write	B1C8 (45512)	30
Reserved				B1E6 (45542)	30
Grp6 Text field 2	Batch field 2 text string (max. 60 characters)	String_60	Read/Write	B204 (45572)	30
Reserved				B222 (45602)	30
Grp6 Text field 3	Batch field 3 text string (max. 60 characters)	String_60	Read/Write	B240 (45632)	30
Reserved				B25E (45662)	30
Grp6 Text field 4	Batch field 4 text string (max. 60 characters)	String_60	Read/Write	B27C (45692)	30
Reserved				B29A (45722)	30
Grp6 Text field 5	Batch field 5 text string (max. 60 characters)	String_60	Read/Write	B2B8 (45752)	30
Reserved				B2D6 (45782)	30
Grp6 Text field 6	Batch field 6 text string (max. 60 characters)	String_60	Read/Write	B2F4 (45812)	30
Reserved				B312 (45842)	30
Spare				B330 (45872)	100

2.4.5 Feature identification table (FIT)

This table allows the host to identify which features are available at the recorder.

Parameter Name	Description	Value	Access	Start Addr. Hex (Dec)	Register Length
Number of features	Number of supported features	3	Read only	CC26 (52262)	1
Feature 1	Indirection Table	1	Read only	CC27 (52263)	1
	Read only indirection table start address (R/O vector)	CD89	Read only	CC28 (52264)	1
	Read/Write indirection table start address (R/W vector)	D18A	Read only	CC29 (52265)	1
	Spare			CC2A (52266)	1
Feature 2	Function codes supported (FC I.D.)	4	Read only	CC2B (52267)	1
	Bit map of supported MODBUS function codes	32940	Read only	CC2C (52268)	1
	Bit 0: 0 = code 1 not supported; 1 = code 1 supported				
	Bit 1: 0 = code 2 not supported; 1 = code 2 supported				
	Bit 2: 0 = code 3 not supported; 1 = code 3 supported				
	Bit 3: 0 = code 4 not supported; 1 = code 4 supported Etc.				
	Bit 15: 0 = code 16 not supported; 1 = code 16 supported				
	Reserved			CC2D (52269)	1
	Reserved			CC2E (52270)	1
Feature 3	Security ID (MODBUS login security feature)	9	Read only	CC2F (52271)	1
	User name		Write only	CC30 (52272)	40
	Password		Write only	CC58 (52312)	40
	Reserved			CC80 (52352)	1
Feature N	100 Spare addresses for further features			CC81 (52353)	100

2.4.6 Indirection tables

The standard MODBUS protocol allows block register reads and writes. This is efficient only if data is grouped contiguously, or nearly so. Indirection tables are a means by which widely spaced register addresses can (in effect) be grouped, offering the host the ability to access a block of user defined data in one single read/write request.

Two configurable tables are available, one for read only parameters, the other for read/write. Each table is in two halves - the lower address half contains the addresses of the registers to be accessed; the higher address half contains the values which have been read or which are to be written.

Notes:

1. Indirection table entries are lost at power off, as a result of a brown-out or if the connection with the host is discontinued.
2. Parameters in IEEE format can be accessed by configuring two successive entries in the table. The registers must be in the order: Even address then Odd address.
Parameters which occupy more than one register can be loaded into the indirection area by using function code 16 (pre-set multiple registers) and the parameter's base address (i.e. the parameter's 1st register).
3. Separate indirection table entries are held for each host - the recorder automatically switches each host to its own indirection table without user intervention.
4. Indirection table addresses (CCE5 to D4E7) cannot be entered in the indirection tables. Any attempt to do so will be ignored.

2.4.6 INDIRECTION TABLES (CONT.)

Table 2.4.6a shows the overall arrangement of the indirection table area. Figures 2.4.6b and 2.4.6c show simple examples of Read only and Read/Write addressing for tables with 6 entries.

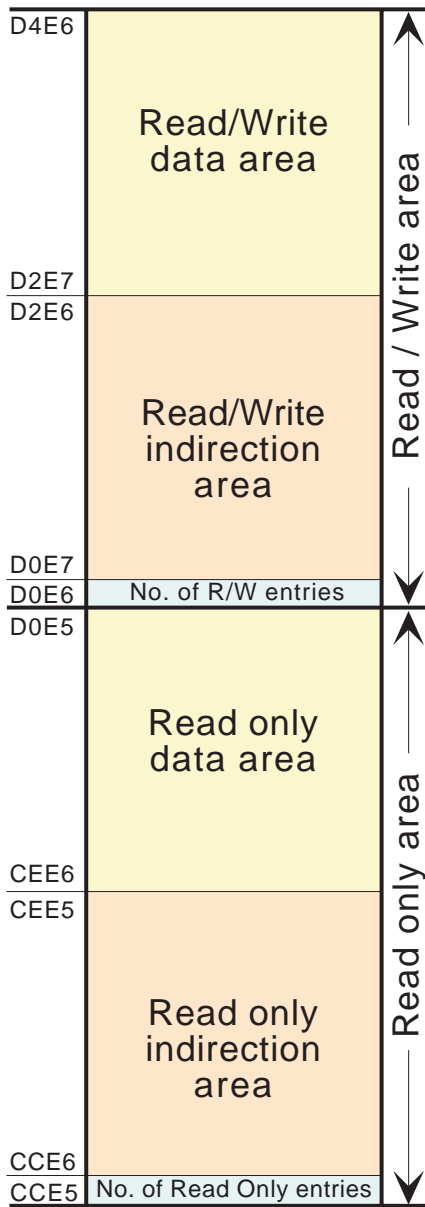

Table 2.4.6a Indirection table areas

2.4.6 INDIRECTION TABLES (CONT.)

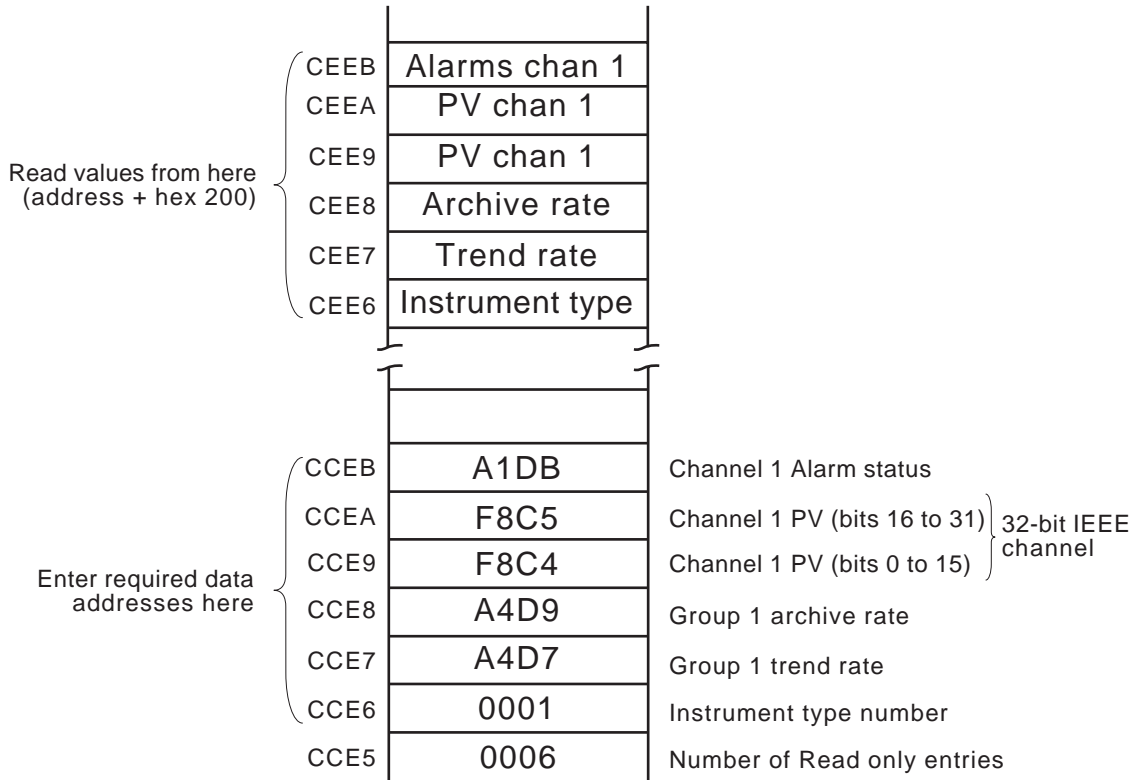

Table 2.4.6b Read only indirection example

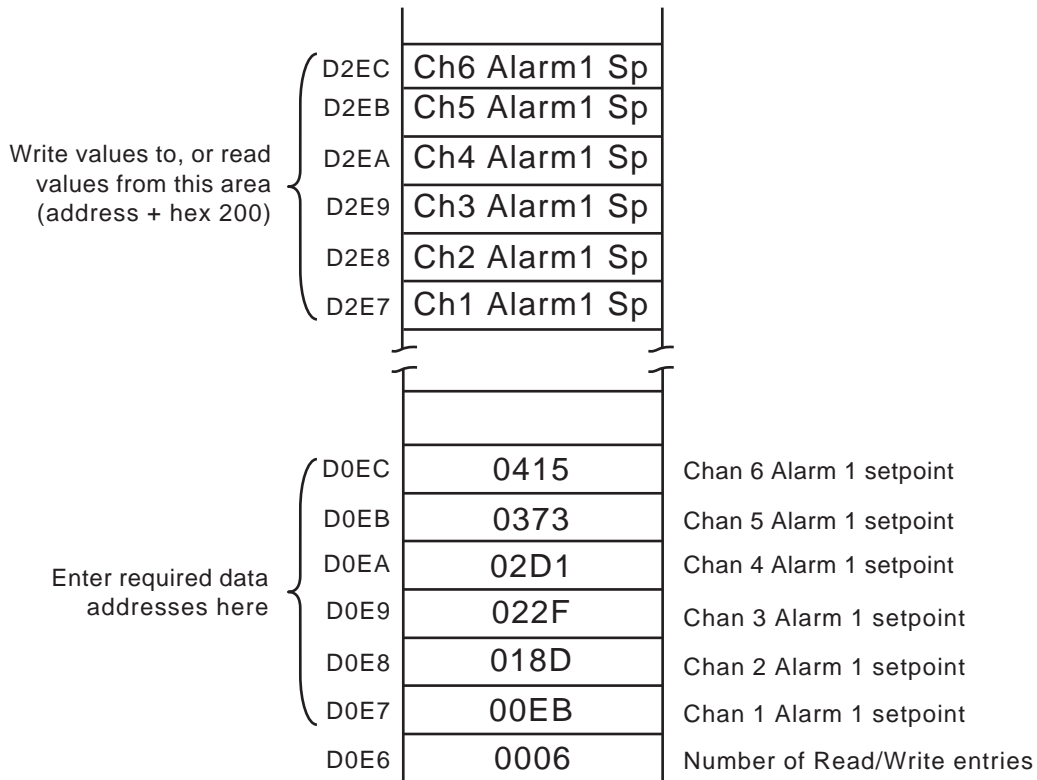

Table 2.4.6c Read/Write indirection example

2.4.7 IEEE 32-bit channel configuration data

Note: A/B switching not supported for this software version.
Span, Zone, Colour etc. are all setting A

The following tables show the hexadecimal addresses for the specified 32-bit floating-point values, for channels 1 to 12. Generally, Parameter address for channel N = Parameter address for channel 1 + 36(N-1) (decimal). The word channel is used as an umbrella term for input channels, maths channels, totalisers etc.

CHANNEL 1

Parameter Name	Description	Type	Access	Start Addr. Hex (Dec)	Register Length
Ch1 span high	Upper span value (Display full scale)	Float	Read only	D4E7 (54503)	2
Ch1 span low	Lower span value (display 'zero')	Float	Read only	D4E9 (54505)	2
Ch1 Zone high	Zone upper value (% of 'chart' width)	Float	Read only	D4EB (54507)	2
Ch1 Zone low	Zone lower value (% of 'chart' width)	Float	Read only	D4ED (54509)	2
Ch1 Alarm 1 setpoint	Trigger setpoint for alarm 1	Float	Read/Write	D4EF (54511)	2
Ch1 Alarm 2 setpoint	Trigger setpoint for alarm 2	Float	Read/Write	D4F1 (54513)	2
Ch1 Alarm 3 setpoint	Trigger setpoint for alarm 3	Float	Read/Write	D4F3 (54515)	2
Ch1 Alarm 4 setpoint	Trigger setpoint for alarm 4	Float	Read/Write	D4F5 (54517)	2
Spare				D4F7 (54519)	20

CHANNEL 2

Parameter Name	Description	Type	Access	Start Addr. Hex (Dec)	Register Length
Ch2 span high	Upper span value (display full scale)	Float	Read only	D50B (54539)	2
Ch2 span low	Lower span value (display 'zero')	Float	Read only	D50D (54541)	2
Ch2 Zone high	Zone upper value (% of 'chart' width)	Float	Read only	D50F (54543)	2
Ch2 Zone low	Zone lower value (% of 'chart' width)	Float	Read only	D511 (54545)	2
Ch2 Alarm 1 setpoint	Trigger setpoint for alarm 1	Float	Read/Write	D513 (54547)	2
Ch2 Alarm 2 setpoint	Trigger setpoint for alarm 2	Float	Read/Write	D515 (54549)	2
Ch2 Alarm 3 setpoint	Trigger setpoint for alarm 3	Float	Read/Write	D517 (54551)	2
Ch2 Alarm 4 setpoint	Trigger setpoint for alarm 4	Float	Read/Write	D519 (54553)	2
Spare				D51B (54555)	20

CHANNEL 3

Parameter Name	Description	Type	Access	Start Addr. Hex (Dec)	Register Length
Ch3 span high	Upper span value (display full scale)	Float	Read only	D52F (54575)	2
Ch3 span low	Lower span value (display 'zero')	Float	Read only	D531 (54577)	2
Ch3 Zone high	Zone upper value (% of 'chart' width)	Float	Read only	D533 (54579)	2
Ch3 Zone low	Zone lower value (% of 'chart' width)	Float	Read only	D535 (54581)	2
Ch3 Alarm 1 setpoint	Trigger setpoint for alarm 1	Float	Read/Write	D537 (54583)	2
Ch3 Alarm 2 setpoint	Trigger setpoint for alarm 2	Float	Read/Write	D539 (54585)	2
Ch3 Alarm 3 setpoint	Trigger setpoint for alarm 3	Float	Read/Write	D53B (54587)	2
Ch3 Alarm 4 setpoint	Trigger setpoint for alarm 4	Float	Read/Write	D53D (54589)	2
Spare				D53F (54591)	20

Note: Alarms 3 and 4 are available only for instruments fitted with 32MB DRAM.

2.4.7 IEEE 32-BIT CHANNEL CONFIGURATION DATA (Cont.)

CHANNEL 4

Parameter Name	Description	Type	Access	Start Addr. Hex (Dec)	Register Length
Ch4 span high	Upper span value (display full scale)	Float	Read only	D553 (54611)	2
Ch4 span low	Lower span value (display 'zero')	Float	Read only	D555 (54613)	2
Ch4 Zone high	Zone upper value (% of 'chart' width)	Float	Read only	D557 (54615)	2
Ch4 Zone low	Zone lower value (% of 'chart' width)	Float	Read only	D559 (54617)	2
Ch4 Alarm 1 setpoint	Trigger setpoint for alarm 1	Float	Read/Write	D55B (54619)	2
Ch4 Alarm 2 setpoint	Trigger setpoint for alarm 2	Float	Read/Write	D55D (54621)	2
Ch4 Alarm 3 setpoint	Trigger setpoint for alarm 3	Float	Read/Write	D55F (54623)	2
Ch4 Alarm 4 setpoint	Trigger setpoint for alarm 4	Float	Read/Write	D561 (54625)	2
Spare				D563 (54627)	20

CHANNEL 5

Parameter Name	Description	Type	Access	Start Addr. Hex (Dec)	Register Length
Ch5 span high	Upper span value (display full scale)	Float	Read only	D577 (54647)	2
Ch5 span low	Lower span value (display 'zero')	Float	Read only	D569 (54649)	2
Ch5 Zone high	Zone upper value (% of 'chart' width)	Float	Read only	D57B (54651)	2
Ch5 Zone low	Zone lower value (% of 'chart' width)	Float	Read only	D57D (54653)	2
Ch5 Alarm 1 setpoint	Trigger setpoint for alarm 1	Float	Read/Write	D57F (54655)	2
Ch5 Alarm 2 setpoint	Trigger setpoint for alarm 2	Float	Read/Write	D581 (54657)	2
Ch5 Alarm 3 setpoint	Trigger setpoint for alarm 3	Float	Read/Write	D583 (54659)	2
Ch5 Alarm 4 setpoint	Trigger setpoint for alarm 4	Float	Read/Write	D585 (54661)	2
Spare				D587 (54663)	20

CHANNEL 6

Parameter Name	Description	Type	Access	Start Addr. Hex (Dec)	Register Length
Ch6 span high	Upper span value (display full scale)	Float	Read only	D59B (54683)	2
Ch6 span low	Lower span value (display 'zero')	Float	Read only	D59D (54685)	2
Ch6 Zone high	Zone upper value (% of 'chart' width)	Float	Read only	D59F (54687)	2
Ch6 Zone low	Zone lower value (% of 'chart' width)	Float	Read only	D5A1 (54689)	2
Ch6 Alarm 1 setpoint	Trigger setpoint for alarm 1	Float	Read/Write	D5A3 (54691)	2
Ch6 Alarm 2 setpoint	Trigger setpoint for alarm 2	Float	Read/Write	D5A5 (54693)	2
Ch6 Alarm 3 setpoint	Trigger setpoint for alarm 3	Float	Read/Write	D5A7 (54695)	2
Ch6 Alarm 4 setpoint	Trigger setpoint for alarm 4	Float	Read/Write	D5A9 (54697)	2
Spare				D5AB (54699)	20

Note: Alarms 3 and 4 are available only for instruments fitted with 32MB DRAM.

2.4.7 IEEE 32-BIT CHANNEL CONFIGURATION DATA (Cont.)

CHANNEL 7

Parameter Name	Description	Type	Access	Start Addr. Hex (Dec)	Register Length
Ch7 span high	Upper span value (display full scale)	Float	Read only	D5BF (54719)	2
Ch7 span low	Lower span value (display 'zero')	Float	Read only	D5C1 (54721)	2
Ch7 Zone high	Zone upper value (% of 'chart' width)	Float	Read only	D5C3 (54723)	2
Ch7 Zone low	Zone lower value (% of 'chart' width)	Float	Read only	D5C5 (54725)	2
Ch7 Alarm 1 setpoint	Trigger setpoint for alarm 1	Float	Read/Write	D5C7 (54727)	2
Ch7 Alarm 2 setpoint	Trigger setpoint for alarm 2	Float	Read/Write	D5C9 (54729)	2
Ch7 Alarm 3 setpoint	Trigger setpoint for alarm 3	Float	Read/Write	D5CB (54731)	2
Ch7 Alarm 4 setpoint	Trigger setpoint for alarm 4	Float	Read/Write	D5CD (54733)	2
Spare				D5CF (54735)	20

CHANNEL 8

Parameter Name	Description	Type	Access	Start Addr. Hex (Dec)	Register Length
Ch8 span high	Upper span value (display full scale)	Float	Read only	D5E3 (54755)	2
Ch8 span low	Lower span value (display 'zero')	Float	Read only	D5E5 (54757)	2
Ch8 Zone high	Zone upper value (% of 'chart' width)	Float	Read only	D5E7 (54759)	2
Ch8 Zone low	Zone lower value (% of 'chart' width)	Float	Read only	D5E9 (54761)	2
Ch8 Alarm 1 setpoint	Trigger setpoint for alarm 1	Float	Read/Write	D5EB (54763)	2
Ch8 Alarm 2 setpoint	Trigger setpoint for alarm 2	Float	Read/Write	D5ED (54765)	2
Ch8 Alarm 3 setpoint	Trigger setpoint for alarm 3	Float	Read/Write	D5EF (54767)	2
Ch8 Alarm 4 setpoint	Trigger setpoint for alarm 4	Float	Read/Write	D5F1 (54769)	2
Spare				D5F3 (54771)	20

CHANNEL 9

Parameter Name	Description	Type	Access	Start Addr. Hex (Dec)	Register Length
Ch9 span high	Upper span value (display full scale)	Float	Read only	D607 (54791)	2
Ch9 span low	Lower span value (display 'zero')	Float	Read only	D609 (54793)	2
Ch9 Zone high	Zone upper value (% of 'chart' width)	Float	Read only	D60B (54795)	2
Ch9 Zone low	Zone lower value (% of 'chart' width)	Float	Read only	D60D (54797)	2
Ch9 Alarm 1 setpoint	Trigger setpoint for alarm 1	Float	Read/Write	D60F (54799)	2
Ch9 Alarm 2 setpoint	Trigger setpoint for alarm 2	Float	Read/Write	D611 (54801)	2
Ch9 Alarm 3 setpoint	Trigger setpoint for alarm 3	Float	Read/Write	D613 (54803)	2
Ch9 Alarm 4 setpoint	Trigger setpoint for alarm 4	Float	Read/Write	D615 (54805)	2
Spare				D617 (54807)	20

Note: Alarms 3 and 4 are available only for instruments fitted with 32MB DRAM.

2.4.7 IEEE 32-BIT CHANNEL CONFIGURATION DATA (Cont.)

CHANNEL 10

Parameter Name	Description	Type	Access	Start Addr. Hex (Dec)	Register Length
Ch10 span high	Upper span value (display full scale)	Float	Read only	D62B (54827)	2
Ch10 span low	Lower span value (display 'zero')	Float	Read only	D62D (54829)	2
Ch10 Zone high	Zone upper value (% of 'chart' width)	Float	Read only	D62F (54831)	2
Ch10 Zone low	Zone lower value (% of 'chart' width)	Float	Read only	D631 (54833)	2
Ch10 Alarm 1 setpoint	Trigger setpoint for alarm 1	Float	Read/Write	D633 (54835)	2
Ch10 Alarm 2 setpoint	Trigger setpoint for alarm 2	Float	Read/Write	D635 (54837)	2
Ch10 Alarm 3 setpoint	Trigger setpoint for alarm 3	Float	Read/Write	D637 (54839)	2
Ch10 Alarm 4 setpoint	Trigger setpoint for alarm 4	Float	Read/Write	D639 (54841)	2
Spare				D63B (54843)	20

CHANNEL 11

Parameter Name	Description	Type	Access	Start Addr. Hex (Dec)	Register Length
Ch11 span high	Upper span value (display full scale)	Float	Read only	D64F (54863)	2
Ch11 span low	Lower span value (display 'zero')	Float	Read only	D651 (54865)	2
Ch11 Zone high	Zone upper value (% of 'chart' width)	Float	Read only	D653 (54867)	2
Ch11 Zone low	Zone lower value (% of 'chart' width)	Float	Read only	D655 (54869)	2
Ch11 Alarm 1 setpoint	Trigger setpoint for alarm 1	Float	Read/Write	D657 (54871)	2
Ch11 Alarm 2 setpoint	Trigger setpoint for alarm 2	Float	Read/Write	D659 (54873)	2
Ch11 Alarm 3 setpoint	Trigger setpoint for alarm 3	Float	Read/Write	D65B (54875)	2
Ch11 Alarm 4 setpoint	Trigger setpoint for alarm 4	Float	Read/Write	D65D (54877)	2
Spare				D65F (54879)	20

CHANNEL 12

Parameter Name	Description	Type	Access	Start Addr. Hex (Dec)	Register Length
Ch12 span high	Upper span value (display full scale)	Float	Read only	D673 (54899)	2
Ch12 span low	Lower span value (display 'zero')	Float	Read only	D675 (54901)	2
Ch12 Zone high	Zone upper value (% of 'chart' width)	Float	Read only	D677 (54903)	2
Ch12 Zone low	Zone lower value (% of 'chart' width)	Float	Read only	D679 (54905)	2
Ch12 Alarm 1 setpoint	Trigger setpoint for alarm 1	Float	Read/Write	D67B (54907)	2
Ch12 Alarm 2 setpoint	Trigger setpoint for alarm 2	Float	Read/Write	D67D (54909)	2
Ch12 Alarm 3 setpoint	Trigger setpoint for alarm 3	Float	Read/Write	D67F (54911)	2
Ch12 Alarm 4 setpoint	Trigger setpoint for alarm 4	Float	Read/Write	D681 (54913)	2
Spare				D683 (54915)	20

Note: Alarms 3 and 4 are available only for instruments fitted with 32MB DRAM.

2.4.8 IEEE Area Channel run-time data

The following tables show the hexadecimal addresses for the specified 32-bit floating-point values, for channels 1 to 12. Generally, Parameter address for channel N = Parameter address for channel 1 + 4(N-1) (decimal).

CHANNEL 1

Parameter Name	Description	Type	Access	Start Addr. Hex (Dec)	Register Length
Channel 1 value	Current process value (PV)	Float	See note	F8C3 (63683)	2
Channel 1 status	Channel status	Enum	Read only	F8C5 (63685)	1
Channel 1 Alarms	0 = Good PV 5 = Ranging error 1 = Channel off 6 = Overflow 2 = Over range 7 = Bad PV 3 = Under range 8 = No data 4 = Hardware error Alarm information Bit 0: 0 = Alarm 1 inactive; 1 = Alarm 1 active Bit 1: 0 = No alarm 1 Ack. required; 1 = Ack. required Bit 2: 1 = Acknowledge alarm 1 Bit 3: Spare Bit 4: 0 = Alarm 2 inactive; 1 = Alarm 2 active Bit 5: 0 = No Alarm 2 Ack. required; 1 = Ack. required Bit 6: 1 = Acknowledge alarm 2 Bit 7: Spare Bit 8: 0 = Alarm 3 inactive; 1 = Alarm 3 active Bit 9: 0 = No alarm 3 Ack. required; 1 = Ack. required Bit 10: 1 = Acknowledge alarm 3 Bit 11: Spare Bit 12: 0 = Alarm 4 inactive; 1 = Alarm 4 active Bit 13: 0 = No Alarm 4 Ack. required; 1 = Ack. required Bit 14: 1 = Acknowledge alarm 4 Bit 15: Spare	Uint16	- Read only Read only Read/Write Read only Read only Read/Write Read only Read only Read/Write Read only Read only Read/Write	F8C6 (63686)	1

CHANNEL 2

Parameter Name	Description	Type	Access	Start Addr. Hex (Dec)	Register Length
Channel 2 value	Current process value (PV)	Float	See note	F8C7 (63687)	2
Channel 2 status	Channel status	Enum	Read only	F8C9 (63689)	1
Channel 2 alarms	0 = Good PV 5 = Ranging error 1 = Channel off 6 = Overflow 2 = Over range 7 = Bad PV 3 = Under range 8 = No data 4 = Hardware error Alarm information Bit 0: 0 = Alarm 1 inactive; 1 = Alarm 1 active Bit 1: 0 = No alarm 1 Ack. required; 1 = Ack. required Bit 2: 1 = Acknowledge alarm 1 Bit 3: Spare Bit 4: 0 = Alarm 2 inactive; 1 = Alarm 2 active Bit 5: 0 = No Alarm 2 Ack. required; 1 = Ack. required Bit 6: 1 = Acknowledge alarm 2 Bit 7: Spare Bit 8: 0 = Alarm 3 inactive; 1 = Alarm 3 active Bit 9: 0 = No alarm 3 Ack. required; 1 = Ack. required Bit 10: 1 = Acknowledge alarm 3 Bit 11: Spare Bit 12: 0 = Alarm 4 inactive; 1 = Alarm 4 active Bit 13: 0 = No Alarm 4 Ack. required; 1 = Ack. required Bit 14: 1 = Acknowledge alarm 4 Bit 15: Spare	Uint16	- Read only Read only Read/Write Read only Read only Read/Write Read only Read only Read/Write Read only Read only Read/Write	F8CA (63690)	1

Notes

1. For measuring channels, access is read only; for derived channels, access is read/write
2. Alarms 3 and 4 are available only for instruments fitted with 32MB DRAM

2.4.8 IEEE AREA CHANNEL RUN-TIME DATA (Cont.)

CHANNEL 3

Parameter Name	Description	Type	Access	Start Addr. Hex (Dec)	Register Length
Channel 3 value	Current process value (PV)	Float	See note	F8CB (63691)	2
Channel 3 status	Channel status 0 = Good PV 5 = Ranging error 1 = Channel off 6 = Overflow 2 = Over range 7 = Bad PV 3 = Under range 8 = No data 4 = Hardware error	Enum	Read only	F8CD (63693)	1
Channel 3 Alarms	Alarm information Bit 0: 0 = Alarm 1 inactive; 1 = Alarm 1 active Bit 1: 0 = No alarm 1 Ack. required; 1 = Ack. required Bit 2: 1 = Acknowledge alarm 1 Bit 3: Spare Bit 4: 0 = Alarm 2 inactive; 1 = Alarm 2 active Bit 5: 0 = No Alarm 2 Ack. required; 1 = Ack. required Bit 6: 1 = Acknowledge alarm 2 Bit 7: Spare Bit 8: 0 = Alarm 3 inactive; 1 = Alarm 3 active Bit 9: 0 = No alarm 3 Ack. required; 1 = Ack. required Bit 10: 1 = Acknowledge alarm 3 Bit 11: Spare Bit 12: 0 = Alarm 4 inactive; 1 = Alarm 4 active Bit 13: 0 = No Alarm 4 Ack. required; 1 = Ack. required Bit 14: 1 = Acknowledge alarm 4 Bit 15: Spare	Uint16	- Read only Read only Read/Write Read only Read only Read/Write Read only Read only Read/Write Read only Read only Read/Write	F8CE (63694)	1

CHANNEL 4

Parameter Name	Description	Type	Access	Start Addr. Hex (Dec)	Register Length
Channel 4 value	Current process value (PV)	Float	See note	F8CF (63695)	2
Channel 4 status	Channel status 0 = Good PV 5 = Ranging error 1 = Channel off 6 = Overflow 2 = Over range 7 = Bad PV 3 = Under range 8 = No data 4 = Hardware error	Enum	Read only	F8D1 (63697)	1
Channel 4 alarms	Alarm information Bit 0: 0 = Alarm 1 inactive; 1 = Alarm 1 active Bit 1: 0 = No alarm 1 Ack. required; 1 = Ack. required Bit 2: 1 = Acknowledge alarm 1 Bit 3: Spare Bit 4: 0 = Alarm 2 inactive; 1 = Alarm 2 active Bit 5: 0 = No Alarm 2 Ack. required; 1 = Ack. required Bit 6: 1 = Acknowledge alarm 2 Bit 7: Spare Bit 8: 0 = Alarm 3 inactive; 1 = Alarm 3 active Bit 9: 0 = No alarm 3 Ack. required; 1 = Ack. required Bit 10: 1 = Acknowledge alarm 3 Bit 11: Spare Bit 12: 0 = Alarm 4 inactive; 1 = Alarm 4 active Bit 13: 0 = No Alarm 4 Ack. required; 1 = Ack. required Bit 14: 1 = Acknowledge alarm 4 Bit 15: Spare	Uint16	- Read only Read only Read/Write Read only Read only Read/Write Read only Read only Read/Write	F8D2 (63698)	1

Notes

1. For measuring channels, access is read only; for derived channels, access is read/write
2. Alarms 3 and 4 are available only for instruments fitted with 32MB DRAM

2.4.8 IEEE AREA CHANNEL RUN-TIME DATA (Cont.)

CHANNEL 5

Parameter Name	Description	Type	Access	Start Addr. Hex (Dec)	Register Length
Channel 5 value	Current process value (PV)	Float	See note	F8D3 (63699)	2
Channel 5 status	Channel status 0 = Good PV 5 = Ranging error 1 = Channel off 6 = Overflow 2 = Over range 7 = Bad PV 3 = Under range 8 = No data 4 = Hardware error	Enum	Read only	F8D5 (63701)	1
Channel 5 Alarms	Alarm information Bit 0: 0 = Alarm 1 inactive; 1 = Alarm 1 active Bit 1: 0 = No alarm 1 Ack. required; 1 = Ack. required Bit 2: 1 = Acknowledge alarm 1 Bit 3: Spare Bit 4: 0 = Alarm 2 inactive; 1 = Alarm 2 active Bit 5: 0 = No Alarm 2 Ack. required; 1 = Ack. required Bit 6: 1 = Acknowledge alarm 2 Bit 7: Spare Bit 8: 0 = Alarm 3 inactive; 1 = Alarm 3 active Bit 9: 0 = No alarm 3 Ack. required; 1 = Ack. required Bit 10: 1 = Acknowledge alarm 3 Bit 11: Spare Bit 12: 0 = Alarm 4 inactive; 1 = Alarm 4 active Bit 13: 0 = No Alarm 4 Ack. required; 1 = Ack. required Bit 14: 1 = Acknowledge alarm 4 Bit 15: Spare	Uint16	- Read only Read only Read/Write Read only Read only Read/Write Read only Read only Read/Write Read only Read only Read/Write	F8D6 (63702)	1

CHANNEL 6

Parameter Name	Description	Type	Access	Start Addr. Hex (Dec)	Register Length
Channel 6 value	Current process value (PV)	Float	See note	F8D7 (63703)	2
Channel 6 status	Channel status 0 = Good PV 5 = Ranging error 1 = Channel off 6 = Overflow 2 = Over range 7 = Bad PV 3 = Under range 8 = No data 4 = Hardware error	Enum	Read only	F8D9 (63705)	1
Channel 6 alarms	Alarm information Bit 0: 0 = Alarm 1 inactive; 1 = Alarm 1 active Bit 1: 0 = No alarm 1 Ack. required; 1 = Ack. required Bit 2: 1 = Acknowledge alarm 1 Bit 3: Spare Bit 4: 0 = Alarm 2 inactive; 1 = Alarm 2 active Bit 5: 0 = No Alarm 2 Ack. required; 1 = Ack. required Bit 6: 1 = Acknowledge alarm 2 Bit 7: Spare Bit 8: 0 = Alarm 3 inactive; 1 = Alarm 3 active Bit 9: 0 = No alarm 3 Ack. required; 1 = Ack. required Bit 10: 1 = Acknowledge alarm 3 Bit 11: Spare Bit 12: 0 = Alarm 4 inactive; 1 = Alarm 4 active Bit 13: 0 = No Alarm 4 Ack. required; 1 = Ack. required Bit 14: 1 = Acknowledge alarm 4 Bit 15: Spare	Uint16	- Read only Read only Read/Write Read only Read only Read/Write Read only Read only Read/Write Read only Read only Read/Write	F8DA (63706)	1

Notes

1. For measuring channels, access is read only; for derived channels, access is read/write
2. Alarms 3 and 4 are available only for instruments fitted with 32MB DRAM

2.4.8 IEEE AREA CHANNEL RUN-TIME DATA (Cont.)

CHANNEL 7

Parameter Name	Description	Type	Access	Start Addr. Hex (Dec)	Register Length
Channel 7 value	Current process value (PV)	Float	See note	F8DB (63707)	2
Channel 7 status	Channel status 0 = Good PV 5 = Ranging error 1 = Channel off 6 = Overflow 2 = Over range 7 = Bad PV 3 = Under range 8 = No data 4 = Hardware error	Enum	Read only	F8DD (63709)	1
Channel 7 Alarms	Alarm information Bit 0: 0 = Alarm 1 inactive; 1 = Alarm 1 active Bit 1: 0 = No alarm 1 Ack. required; 1 = Ack. required Bit 2: 1 = Acknowledge alarm 1 Bit 3: Spare Bit 4: 0 = Alarm 2 inactive; 1 = Alarm 2 active Bit 5: 0 = No Alarm 2 Ack. required; 1 = Ack. required Bit 6: 1 = Acknowledge alarm 2 Bit 7: Spare Bit 8: 0 = Alarm 3 inactive; 1 = Alarm 3 active Bit 9: 0 = No alarm 3 Ack. required; 1 = Ack. required Bit 10: 1 = Acknowledge alarm 3 Bit 11: Spare Bit 12: 0 = Alarm 4 inactive; 1 = Alarm 4 active Bit 13: 0 = No Alarm 4 Ack. required; 1 = Ack. required Bit 14: 1 = Acknowledge alarm 4 Bit 15: Spare	Uint16	- Read only Read only Read/Write Read only Read only Read/Write Read only Read only Read/Write Read only Read only Read/Write	F8DE (63710)	1

CHANNEL 8

Parameter Name	Description	Type	Access	Start Addr. Hex (Dec)	Register Length
Channel 8 value	Current process value (PV)	Float	See note	F8DF (63711)	2
Channel 8 status	Channel status 0 = Good PV 5 = Ranging error 1 = Channel off 6 = Overflow 2 = Over range 7 = Bad PV 3 = Under range 8 = No data 4 = Hardware error	Enum	Read only	F8E1 (63713)	1
Channel 8 alarms	Alarm information Bit 0: 0 = Alarm 1 inactive; 1 = Alarm 1 active Bit 1: 0 = No alarm 1 Ack. required; 1 = Ack. required Bit 2: 1 = Acknowledge alarm 1 Bit 3: Spare Bit 4: 0 = Alarm 2 inactive; 1 = Alarm 2 active Bit 5: 0 = No Alarm 2 Ack. required; 1 = Ack. required Bit 6: 1 = Acknowledge alarm 2 Bit 7: Spare Bit 8: 0 = Alarm 3 inactive; 1 = Alarm 3 active Bit 9: 0 = No alarm 3 Ack. required; 1 = Ack. required Bit 10: 1 = Acknowledge alarm 3 Bit 11: Spare Bit 12: 0 = Alarm 4 inactive; 1 = Alarm 4 active Bit 13: 0 = No Alarm 4 Ack. required; 1 = Ack. required Bit 14: 1 = Acknowledge alarm 4 Bit 15: Spare	Uint16	- Read only Read only Read/Write Read only Read only Read/Write Read only Read only Read/Write	F8E2 (63714)	1

Notes

1. For measuring channels, access is read only; for derived channels, access is read/write
2. Alarms 3 and 4 are available only for instruments fitted with 32MB DRAM

2.4.8 IEEE AREA CHANNEL RUN-TIME DATA (Cont.)

CHANNEL 9

Parameter Name	Description	Type	Access	Start Addr. Hex (Dec)	Register Length
Channel 9 value	Current process value (PV)	Float	See note	F8E3 (63715)	2
Channel 9 status	Channel status 0 = Good PV 5 = Ranging error 1 = Channel off 6 = Overflow 2 = Over range 7 = Bad PV 3 = Under range 8 = No data 4 = Hardware error	Enum	Read only	F8E5 (63717)	1
Channel 9 Alarms	Alarm information Bit 0: 0 = Alarm 1 inactive; 1 = Alarm 1 active Bit 1: 0 = No alarm 1 Ack. required; 1 = Ack. required Bit 2: 1 = Acknowledge alarm 1 Bit 3: Spare Bit 4: 0 = Alarm 2 inactive; 1 = Alarm 2 active Bit 5: 0 = No Alarm 2 Ack. required; 1 = Ack. required Bit 6: 1 = Acknowledge alarm 2 Bit 7: Spare Bit 8: 0 = Alarm 3 inactive; 1 = Alarm 3 active Bit 9: 0 = No alarm 3 Ack. required; 1 = Ack. required Bit 10: 1 = Acknowledge alarm 3 Bit 11: Spare Bit 12: 0 = Alarm 4 inactive; 1 = Alarm 4 active Bit 13: 0 = No Alarm 4 Ack. required; 1 = Ack. required Bit 14: 1 = Acknowledge alarm 4 Bit 15: Spare	Uint16	- Read only Read only Read/Write Read only Read only Read/Write Read only Read only Read/Write Read only Read only Read/Write	F8E6 (63718)	1

CHANNEL 10

Parameter Name	Description	Type	Access	Start Addr. Hex (Dec)	Register Length
Channel 10 value	Current process value (PV)	Float	See note	F8E7 (63719)	2
Channel 10 status	Channel status 0 = Good PV 5 = Ranging error 1 = Channel off 6 = Overflow 2 = Over range 7 = Bad PV 3 = Under range 8 = No data 4 = Hardware error	Enum	Read only	F8E9 (63721)	1
Channel 10 alarms	Alarm information Bit 0: 0 = Alarm 1 inactive; 1 = Alarm 1 active Bit 1: 0 = No alarm 1 Ack. required; 1 = Ack. required Bit 2: 1 = Acknowledge alarm 1 Bit 3: Spare Bit 4: 0 = Alarm 2 inactive; 1 = Alarm 2 active Bit 5: 0 = No Alarm 2 Ack. required; 1 = Ack. required Bit 6: 1 = Acknowledge alarm 2 Bit 7: Spare Bit 8: 0 = Alarm 3 inactive; 1 = Alarm 3 active Bit 9: 0 = No alarm 3 Ack. required; 1 = Ack. required Bit 10: 1 = Acknowledge alarm 3 Bit 11: Spare Bit 12: 0 = Alarm 4 inactive; 1 = Alarm 4 active Bit 13: 0 = No Alarm 4 Ack. required; 1 = Ack. required Bit 14: 1 = Acknowledge alarm 4 Bit 15: Spare	Uint16	- Read only Read only Read/Write Read only Read only Read/Write Read only Read only Read/Write Read only Read only Read/Write	F8EA (63722)	1

Notes

1. For measuring channels, access is read only; for derived channels, access is read/write
2. Alarms 3 and 4 are available only for instruments fitted with 32MB DRAM

2.4.8 IEEE AREA CHANNEL RUN-TIME DATA (Cont.)

CHANNEL 11

Parameter Name	Description	Type	Access	Start Addr. Hex (Dec)	Register Length
Channel 11 value	Current process value (PV)	Float	See note	F8EB (63723)	2
Channel 11 status	Channel status 0 = Good PV 5 = Ranging error 1 = Channel off 6 = Overflow 2 = Over range 7 = Bad PV 3 = Under range 8 = No data 4 = Hardware error	Enum	Read only	F8ED (63725)	1
Channel 11 Alarms	Alarm information Bit 0: 0 = Alarm 1 inactive; 1 = Alarm 1 active Bit 1: 0 = No alarm 1 Ack. required; 1 = Ack. required Bit 2: 1 = Acknowledge alarm 1 Bit 3: Spare Bit 4: 0 = Alarm 2 inactive; 1 = Alarm 2 active Bit 5: 0 = No Alarm 2 Ack. required; 1 = Ack. required Bit 6: 1 = Acknowledge alarm 2 Bit 7: Spare Bit 8: 0 = Alarm 3 inactive; 1 = Alarm 3 active Bit 9: 0 = No alarm 3 Ack. required; 1 = Ack. required Bit 10: 1 = Acknowledge alarm 3 Bit 11: Spare Bit 12: 0 = Alarm 4 inactive; 1 = Alarm 4 active Bit 13: 0 = No Alarm 4 Ack. required; 1 = Ack. required Bit 14: 1 = Acknowledge alarm 4 Bit 15: Spare	Uint16	- Read only Read only Read/Write Read only Read only Read/Write Read only Read only Read/Write Read only Read only Read/Write	F8EE (63726)	1

CHANNEL 12

Parameter Name	Description	Type	Access	Start Addr. Hex (Dec)	Register Length
Channel 12 value	Current process value (PV)	Float	See note	F8EF (63727)	2
Channel 12 status	Channel status 0 = Good PV 5 = Ranging error 1 = Channel off 6 = Overflow 2 = Over range 7 = Bad PV 3 = Under range 8 = No data 4 = Hardware error	Enum	Read only	F8F1 (63729)	1
Channel 12 alarms	Alarm information Bit 0: 0 = Alarm 1 inactive; 1 = Alarm 1 active Bit 1: 0 = No alarm 1 Ack. required; 1 = Ack. required Bit 2: 1 = Acknowledge alarm 1 Bit 3: Spare Bit 4: 0 = Alarm 2 inactive; 1 = Alarm 2 active Bit 5: 0 = No Alarm 2 Ack. required; 1 = Ack. required Bit 6: 1 = Acknowledge alarm 2 Bit 7: Spare Bit 8: 0 = Alarm 3 inactive; 1 = Alarm 3 active Bit 9: 0 = No alarm 3 Ack. required; 1 = Ack. required Bit 10: 1 = Acknowledge alarm 3 Bit 11: Spare Bit 12: 0 = Alarm 4 inactive; 1 = Alarm 4 active Bit 13: 0 = No Alarm 4 Ack. required; 1 = Ack. required Bit 14: 1 = Acknowledge alarm 4 Bit 15: Spare	Uint16	- Read only Read only Read/Write Read only Read only Read/Write Read only Read only Read/Write	F8F2 (63730)	1

Notes

1. For measuring channels, access is read only; for derived channels, access is read/write
2. Alarms 3 and 4 are available only for instruments fitted with 32MB DRAM

2.4.9 Permanent ID table

This table contains information relating to the recorder, and also gives the start address of the feature identification table (FIT).

FFF4	HHHH	Checksum
FFF3	CC26	FIT start address
FFF2	0001	Version ID
FFF1	5000	Product ID
FFF0	0500	Company ID

Table 2.4.9 Permanent ID table

2.5 DATA TRANSMISSION

Each message (request or response) is packaged in the (MODBUS) frame shown below. The messages consist of a 7 byte prefix, followed by the function code (in hex), followed by the relevant data bytes, the number and content of which depend on the function code, as described in subsequent sections.

Byte 0	Byte 1	Byte 2	Byte 3	Byte 4	Byte 5	Byte 6	Byte 7	Bytes 8 onwards
Transaction identifier (usually 00)	Transaction identifier (usually 00)	Protocol identifier (00)	Protocol identifier (00)	Always 00	Number of bytes following	Recorder identifier (usually 00)	MODBUS function code (hex)	Data (Depends on function code)

Figure 2.5 MODBUS package

Notes:

- 1 The transaction identifier has no active function - the recorder just copies the bytes from the request message to the response message.
- 2 The recorder identifier has no active function - the recorder just copies the byte from the request message to the response message.
3. The protocol identifier bytes are always zero.

FUNCTION CODES AND EXCEPTION CODES

Refer to [section 2.2.1](#) for lists of function codes and exception codes supported.

TEXT STRINGS

When sending text strings, such as Batch fields, the final character must be followed by one or two 'Null' characters. The number of bytes in the text string (including the null) must be even, even if this means adding two nulls at the end of the message instead of one.

For example, the text string: "Batch Number" should be sent as

Ba tc hSpace Nu mb er NullNull, or Ba tc hSpace Nu mb er SpaceNull
 where each pair of characters occupies one 16-bit word. Similarly, the text string 'Batch Number:' would be sent as
 Ba tc hSpace Nu mb er :null,

but only one Null character is required to provide an even number of bytes.

2.5.1 Function code 03

REQUEST

The bytes after the 7-byte prefix described above are:

Function code (03) (1 byte)

Register start address (2 bytes)

Word count (Total number of registers) (1 to 125 decimal; 1 to 7D hex) (2 bytes)

Thus to read Channel 5 descriptor (start address 031F - 10 registers altogether) the following request (as described in figure 2.5.1a) would be transmitted:

0000000000060003031F000A

Byte 0	Byte 1	Byte 2	Byte 3	Byte 4	Byte 5	Byte 6	Byte 7	Byte 8	Byte 9	Byte 10	Byte 11
00	00	00	00	00	06	00	03	03	1F	00	0A
Transaction identifier	Transaction identifier	Protocol identifier	Protocol identifier	Always 00	Number of bytes following	Recorder identifier	MODBUS function code (hex)	Register start address high byte	Register start address low byte	Word count high byte	Word count low byte

Figure 2.5.1a Function code 03 request example

RESPONSE

As a response to a request, the recorder returns a similar message, but the function code (03) is followed by:

Byte count (= 2 x the number of register values requested) in hex (1 byte)

Value of register at start address (2 bytes)

Value of register at start address + 1 (2 bytes)

etc.

etc.

Value of final register (2 bytes)

Thus as a response to the above request for channel 5 descriptor, the following message (as expanded in figure 2.5.1b) would be returned to the host (assuming channel descriptor to be: Channel 5 Descriptor):

0000000000170003144368616E6E656C20352044657363726970746F72

Byte 0	Byte 1	Byte 2	Byte 3	Byte 4	Byte 5	Byte 6	Byte 7	Byte 8	Byte 9	Byte 10	Byte 11
00	00	00	00	00	17	00	03	14	43	68	61
Transaction identifier	Transaction identifier	Protocol identifier	Protocol identifier	Always 00	Number of bytes following (hex)	Recorder identifier	MODBUS function code (hex)	Byte count (No of registers x 2) (Hex)	ASCII C (Hex)	ASCII h (Hex)	ASCII a (Hex)

Byte 12	Byte 13	Byte 14	Byte 15	Byte 16	Byte 17	Byte 18	Byte 19	Byte 20	Byte 21	Byte 22	Byte 23
6E	6E	65	6C	20	35	20	44	65	73	63	72
ASCII n (Hex)	ASCII n (Hex)	ASCII e (Hex)	ASCII l (Hex)	ASCII space (Hex)	ASCII 5 (Hex)	ASCII space (Hex)	ASCII D (Hex)	ASCII e (Hex)	ASCII s (Hex)	ASCII c (Hex)	ASCII r (Hex)

Byte 24	Byte 25	Byte 26	Byte 27	Byte 28
69	70	74	6F	72
ASCII i (Hex)	ASCII p (Hex)	ASCII t (Hex)	ASCII o (Hex)	ASCII r (Hex)

Figure 2.5.1b Function code 03 response example

EXCEPTION RESPONSES

Byte 0 = Function code 83 (hex) (i.e. Hex (80 + function code))

Byte 1 = Exception code 01 (Illegal function) or 02 (Invalid data address)

2.5.2 Function code 04

This is identical with function code 03, except that 04 must be used as the function code and the exception response Function code is 84 (hex) not 83.

2.5.3 Function code 06

REQUEST

This is used to write a value to a single register. The bytes after the 7-byte prefix described in [section 2.5](#), above are:
 Function code (06) (1 byte)
 Register address (2 bytes)
 Value to be written (2 bytes)

Thus to write a value of 80 degrees as Alarm 1 setpoint for channel 3 (register address 022F), the following request (as detailed in figure 2.5.3) would be transmitted to the recorder:

0000000000060006022F0050

Byte 0	Byte 1	Byte 2	Byte 3	Byte 4	Byte 5	Byte 6	Byte 7	Byte 8	Byte 9	Byte 10	Byte 11
00	00	00	00	00	06	01	06	02	2F	00	50
Transaction identifier	Transaction identifier	Protocol identifier	Protocol identifier	Always 00	Number of bytes following	Recorder ID	MODBUS function code (hex)	Register start address high byte	Register start address low byte	Value high byte (hex)	Value low byte (hex)

Figure 2.5.3 Function code 06 request/response example

RESPONSE

As a response to a request, the recorder returns a message identical with the request message.

EXCEPTION RESPONSES

Byte 0 = Function code 86 (hex) (i.e. Hex (80 + function code))
 Byte 1 = Exception code 01 (Illegal function) or 02 (Invalid data address)

2.5.4 Function code 08

This is used to initiate a loop-back test. The bytes after the 7-byte prefix described in [section 2.5](#), above are:

Function code (08) (1 byte)
 Subfunction code (00 00) (2 bytes)
 Query data (loopback value) (HH HH) (2 bytes)

Thus to initiate a loopback test (using, as an example, 'P' 'Q' as the query data), the following request (as detailed in figure 2.5.4) is transmitted to the recorder:

000000000006000800005051

The response to the receipt of such a message should be to 'echo' the request back to the host.

Byte 0	Byte 1	Byte 2	Byte 3	Byte 4	Byte 5	Byte 6	Byte 7	Byte 8	Byte 9	Byte 10	Byte 11
00	00	00	00	00	06	00	08	00	00	50	51
Transaction identifier	Transaction identifier	Protocol identifier	Protocol identifier	Always 00	Number of bytes following	Recorder identifier	MODBUS function code (hex)	Subfunction code high byte	Subfunction code low byte	Query data high byte (ASCII 'P') (Hex)	Query data low byte (ASCII 'Q') (Hex)

Figure 2.5.4 Function code 08 (loopback test) example

2.5.5 Function code 16 (Hex 10)

REQUEST

This is used to write values to multiple registers. The bytes after the 7-byte prefix described in [section 2.5](#), above are:
 Function code (10) (1 byte)
 Register Start address (2 bytes)
 Word count (Total number of registers to be written) (1 to 100 decimal; 1 to 64 hex) (2 bytes)
 Byte count (B) (2 x word count) (1 byte)
 Values to be written (2B bytes).

Thus to write "Batch Number" as batch field 1 for group 1 (start address A57F), the following message (expanded in figure 2.5.5a) would be transmitted to the recorder:

0000000000150010A57F00070E4261746368204E756D6265720000

Byte 0	Byte 1	Byte 2	Byte 3	Byte 4	Byte 5	Byte 6	Byte 7	Byte 8	Byte 9	Byte 10	Byte 11	Byte 12
00	00	00	00	00	15	00	10	A5	7F	00	07	0E
Transaction identifier	Transaction identifier	Protocol identifier	Protocol identifier	Always 00	Number of bytes to follow (hex)	Recorder identifier	MODBUS function code (hex)	Base address High byte	Base address Low byte	Word count High byte	Word count Low byte	Byte count

Byte 13	Byte 14	Byte 15	Byte 16	Byte 17	Byte 18	Byte 19	Byte 20	Byte 21	Byte 22	Byte 23	Byte 24	Byte 25	Byte 26
42	61	74	63	68	20	4E	75	6D	62	65	72	00	00
ASCII B (Hex)	ASCII a (Hex)	ASCII t (Hex)	ASCII c (Hex)	ASCII h (Hex)	ASCII space (Hex)	ASCII N (Hex)	ASCII u (Hex)	ASCII m (Hex)	ASCII b (Hex)	ASCII e (Hex)	ASCII r (Hex)	ASCII Null	ASCII Null

Figure 2.5.5a Function code 16 request example

RESPONSE

The response message (detailed in figure 2.5.5b) after the 7-byte prefix described in [section 2.5](#), above is:

Function code 10 (1 byte)
 Start address (2 bytes)
 Word count (2 bytes)

Thus, the response to the above batch field request would be:

000000000060010A57F0007

Byte 0	Byte 1	Byte 2	Byte 3	Byte 4	Byte 5	Byte 6	Byte 7	Byte 8	Byte 9	Byte 10	Byte 11
00	00	00	00	00	06	00	10	A5	7F	00	07
Transaction identifier	Transaction identifier	Protocol identifier	Protocol identifier	Always 00	Number of bytes following (hex)	Recorder ID	MODBUS function code (hex)	Base address High byte	Base address Low byte	Word count High byte	Word count Low byte

Figure 2.5.5b Function code 16 response example

EXCEPTION RESPONSES

Byte 0 = Function code 90 (hex) (i.e. Hex (80 + function code))
 Byte 1 = Exception code 01 (Illegal function) or 02 (Invalid data address)

Note: Function code 16 can be used to write multiple registers into the indirection table area, for example, by writing the base register address of a 32-bit channel value (e.g. channel 3 - start address: F994) into location D18B.

3 MODBUS MASTER COMMS

3.1 INTRODUCTION

This unit can be used as a Modbus Master unit, as well as a Modbus Slave. The instrument can communicate using the Ethernet (RJ45) connection, or by means of the serial communications option board (described below, in section 4) or both simultaneously.

Master Configuration consists of entering a Modbus Address, and, for Ethernet connection, an IP address or DNS path name for each of the available remote devices which are to be used as slaves. The configuration also allows three different priority intervals to be entered, and read/write parameters can be configured to be accessed at one of these three rates.

The unit comes complete with a number of 'Profiles' for known instruments. This allows it to 'recognise' an instrument as a slave type, and simplifies the read/write process for 'known' instruments, by presenting commonly used Parameters by name. Other parameters can be accessed by entering the relevant register's address. The unit will also communicate with 'third party' instruments, but in such a case, the user has to define the required read/write register addresses derived from data supplied by the manufacturer of the instrument.

Once the remote unit has been recognised by the master, the master and slave units can be configured to carry out the following:

1. By setting a master input channel to: Type = 'Master Comms', selected parameters can be read by the master from a selected slave. This master channel can then be included in display groups, can have alarm setpoints, run jobs etc, independently of the original channel. In a similar way, maths functions can be read by setting a master Maths channel to: Function = 'Master Comms'.
2. The 'Demand Write' feature can write values to a selected parameter in a selected slave, as a one-shot update. Demand Writes can be initiated by operator action, or they can be initiated by job action or (if the User Screens option is fitted), by Operator Key action.
3. For slaves whose input and/or maths channels can be set to 'Slave Comms' or 'Serial Comms' etc., the master's 'Output channels' feature can copy master input or maths channels to a selected slave, as a continuous process. See section 3.5 for full details.

Note: If reading from or writing to more than one instrument, it is recommended that some thought be given to instrument and point descriptors, as confusion can easily arise. This is particularly true if Remote Viewer is connected to a master which has several slaves attached.

An example configuration is given in [section 3.6](#) showing how to set up a master unit to read inputs from two slaves, and to re-write one of these channels to a third slave.

3.2 MASTER COMMS CONFIGURATION MENU

A typical master comms configuration page is shown in figure 3.2, below.

Note: For the sake of completeness, figure 3.2 shows all possible fields, even though some are actually mutually exclusive (e.g. 'Login Required' does not appear for 'Profile = Third party').

The screenshot shows the Master Comms configuration menu with the following fields and values:

- High Priority interval: 0.125 Seconds
- Medium priority interval: 1 Seconds
- Low priority interval: 2 Seconds
- Store diagnostics:
- Slave: 1) Remote Device 1
- Enable:
- Online:
- Descriptor: Remote Device 1
- Network: Ethernet (Note: Select 'Ethernet' or 'Serial')
- IP Address: 149.121.30.0 (Note: IP Address field appears only if 'Ethernet' selected as Network type.)
- Modbus address: 1
- Detect This Slave:
- Profile: Third Party
- Timeout: 250 ms
- Retry: 3
- Max Block Size: 124 Register
- Share Socket:
- Login Required: (Note: Appears only if Profile slave type supports login security)
- Username: Username
- Password: *****

Buttons at the bottom: Apply, Discard, Detect All Slaves

Figure 3.2 Master Comms configuration menu.

3.2.1 Configurable parameters

Priority intervals This allows three levels of update rate to be entered. These rates are used in point configuration, to define how often a value is read. In order to optimise the performance of the serial link, it is recommended that the slowest rate consistent with requirements be selected. The interval is entered in multiples of 1/8th second (0.125 seconds).

In some cases, two update rates can be defined. For example, when reading a Process Value (PV) channel from a some slaves, it is possible to set the reading interval of the PV to the shortest available, and the reading interval of other, less frequently changing, values (scale low/high for example) to a slower rate.

Store Diagnostics If enabled, diagnostics information (section 3.7) is kept in non-volatile memory, and is thus retained during power cycling.

Slave A picklist of slaves, initially called 'Remote Device N'. When the device is detected, this name changes to the detected Instrument's Descriptor (if any) or a default tag. The slave name can be edited in the 'Descriptor' entry field below.

3.2.1 CONFIGURABLE PARAMETERS (Cont.)

Enable	If this window is not selected, none of the following fields appears, and the Remote Device cannot be accessed.
Online	If enabled, normal communications with the slave are carried out. When disabled, the connection with the slave to be terminated.
Descriptor	Allows a new name for the slave device to be entered. (This name is used only within the master - it does not overwrite the Instrument Descriptor in the slave itself).
Network	Select Ethernet or Serial. All the slaves on the link must have the same communications parameter values (e.g. Baud Rate) as are set for the master. See Section 4.3 for Serial Communications Configuration details.

Note: Serial appears as a selection choice only if 'Protocol' has been set to 'Modbus Master' in the Serial Comms Configuration ([section 4.3](#)).

IP Address	This field appears only if Network = Ethernet. This must match the IP address or DNS name of the slave. For this unit, this information is to be found in Network/Address and Network/Name respectively. For other instruments, refer to the documentation supplied with those instruments.
Modbus Address	For Ethernet links, Modbus addresses are associated with the IP address. This means that, for any IP address, the range of Modbus addresses used for slaves can (if required) be the same as the range used by a unit with a different IP address. For Serial communications, each unit (including the master) must have a unique Modbus address. For the unit described by this manual, the Modbus address is accessed in 'Instrument' configuration (section 4.3.1 of the User Guide). For other instruments, refer to the documentation supplied with those instruments.
Profile	A pick list of supported instrument types. Third party is used as a default, and for non-listed instrument types. This field is updated automatically if the slave is Detected.
Timeout	Allows a timeout period to be set for the read/write process. See 'Retry' below, and 'Disable Retries' in section 3.4.1 .
Retry	Allows entry of the number of times the master attempts to get a response from the slave, before aborting. If not successful, an error message appears.
Max Block size	Always 124 for supported instruments, this field is editable for 'Third party' instruments. The maximum block length supported by a particular instrument is found from that instrument's documentation.
Share Socket	This item appears only for slaves with Network = Ethernet. When enabled, allows a reduction in the number of links between a master and multiple slaves. See ' Share Socket ', below for more details. Generally, it is recommended that this item is left at the default for the particular slave being configured.
Login Required	Some slaves require a user name and password to be entered before access can be gained. The user name and password set here in the master Comms configuration must match those of the slave. For this type of instrument, the user name is the 'Remote user name' and the password is the 'Remote password' set up in the Security/Access configuration (section 4.4.1 of the User Guide supplied with this unit). Password is necessary only when Modbus security disabled is not selected in 'Instrument' configuration (section 4.3.1 of the User Guide). For other types of instrument, refer to the documentation supplied with that instrument.
Username/Password	See Login Required, immediately above

DETECT THIS SLAVE

This button causes the master to search for the slave set up on this configuration page. If the search is successful, the Remote Device name changes to the instrument name or default tag.

3.2.1 CONFIGURABLE PARAMETERS (Cont.)

DETECT ALL SLAVES

This is used to detect any slaves connected to the system, within certain search parameters.

Operation of the button calls a display page (figure 3.2.1a) which allows the entry of a start IP address, a range of IP addresses, and a range of Modbus addresses. Once the search information has been entered, operation of the Start key causes the unit to search for any instruments which respond to the search criteria. Once 16 instruments have been found, the search is aborted. In order to 'see' other instruments, the IP or Modbus address range must be edited.

Found instruments will be assigned to the 'Remote Device' list, overwriting, temporarily, any instruments previously configured there. The list becomes permanent when the 'Apply' key is operated, but any of the slaves can be edited, if required, prior to this.

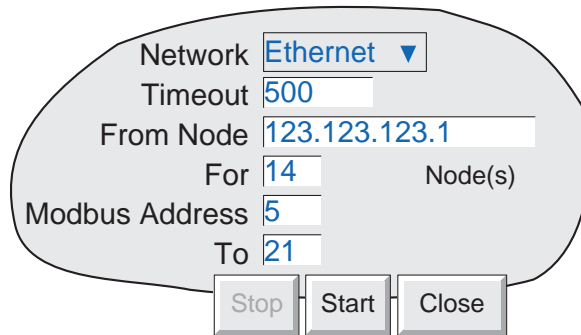

Figure 3.2.1a Detect all slaves set-up menu

In the above example, the search is carried out for all devices with Modbus addresses in the range 5 to 21 inclusive, associated with instruments which have IP addresses between 123.123.123.1 and 123.123.123.14 inclusive.

The 'Autodetect' page displays the progress of the search. Figure 3.2.1b shows how the display lists the found instruments along with their IP addresses with Modbus address appended. For example, the top two lines show that devices with Modbus addresses 1 and 2 were detected at IP address 123.123.123.7.

Note: On the real screen, if the instrument type is recognised, the word 'instrument' is replaced by the instrument type ID.

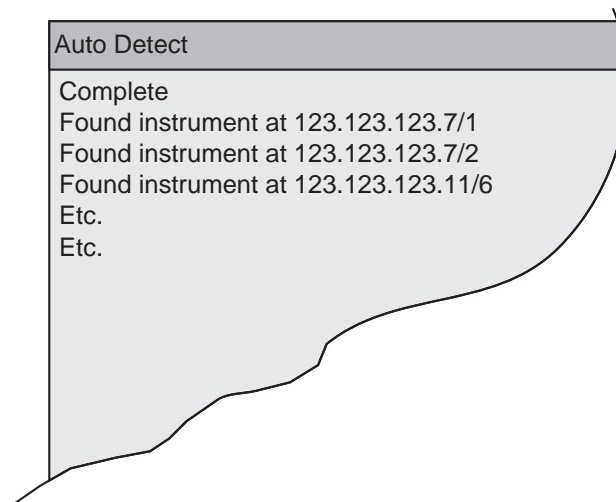

Figure 3.2.1b Autodetect results

3.2.1 CONFIGURABLE PARAMETERS (Cont.)

SHARE SOCKET

This advanced configuration feature is used to improve communications performance, to take advantage of the higher speed of Ethernet links compared with ‘Serial’ links. It is recommended that the default value (enabled or disabled according to type) be left as despatched from the factory, unless there is good reason to change it.

A socket is the name given to a logical connection between two Ethernet nodes. The establishment and maintenance of sockets is controlled by the recorder, and the user has no control other than to enable or disable the ‘Share sockets’ facility. The share socket feature is available only for slaves configured as Ethernet devices (i.e. Network = Ethernet).

The upper illustration in figure 3.2.1c, shows master 1 communicating with slaves 1 to n via an Ethernet-to-Serial converter, called a Modbus Gateway. In such a case, it is more efficient to allow all the slaves to communicate over one link between master 1 and master 2, than to establish individual links between master 1 and each of the slaves. In this example, ‘Share sockets’ should be enabled.

The lower illustration show a similar situation, except that master 2 is not just a gateway, but is a measuring device in its own right. In such a case, Socket 1 is used for high speed communications between master 1 and master 2, and Socket 2 is used to link master 1 to the slaves individually. In this case ‘Share Sockets’ should be disabled for master 2, and enabled for all other devices.

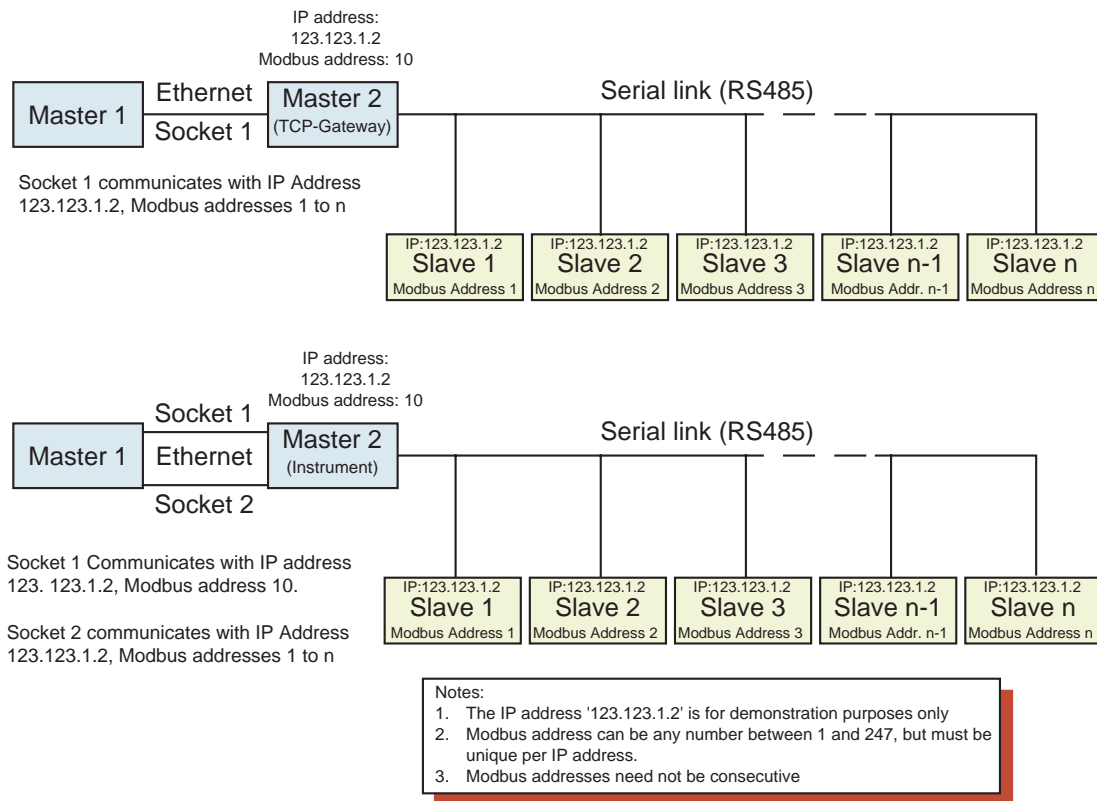

Figure 3.2.1c Share socket examples

3.3 MASTER COMMS CHANNEL CONFIGURATION

This display page shown below is called from the Operator/Config/Channels as described in section 4.3.3 of the User Guide supplied with this unit. A similar page appears in the Operator/Config/Maths configuration (Options Manual section 3.1). The actual picklists which appear, depend entirely on the type or model of instrument being read from. It is assumed that the user knows which parameters are to be accessed.

Section 3.3.1 shows a typical input channel configuration page with 'Master Comms' selected as Input Type, and a recorder or data acquisition unit as slave. Section 3.3.2 is similar but for a slave controller. Section 3.3.3 describes the situation where 'User Defined' has been selected as Parameter. In such a case, the user must determine the required register number from the documentation supplied with the slave.

Note: For completeness, figures 3.3.1, 3.3.2 and 3.3.3 show all possible configuration fields. The fields that actually appear are slave-model, and parameter dependent.

3.3.1 Recorder/Data acquisition unit configurable parameters

Channel Number 1) Read 1 ▾ ← Copies descriptor entry

Value -0.4670 Unadjusted

Input Type Master Comms ▾

Slave 1) Furn 1 Recorder ▾ ← Select required slave

Digital

Parameter Process Value ▾ ← Select required slave parameter type

Scaling None ▾ ← Appears only for some slave types

Point Type Channel ▾ } Select Required Slave parameter point

Point Number 1

Process Value Medium Priority ▾ ← Select iteration rate for parameter update

PV Format Numeric ▾

Span Low 0 Units

Span High 1 Units

Zone Low 0 %

Zone High 100 %

Max Decimal Digits 4

Colour 0

Units Units

Descriptor Read 1

Alarm Number 1

Enable Trigger ▾

Apply Discard

Figure 3.3.1 Channel configuration page - Typical Recorder

3.3.1 RECORDER/DAQ CONFIGURABLE PARAMETERS (Cont.)

TYPICAL RECORDER PARAMETERS

The following parameters may be accessible from a recorder or data acquisition unit, depending on model number. Figure 3.3.1, above, refers

Notes:

1. Items such as Scale, Zone and descriptor may be editable (white background) or not (grey background), depending on model.
2. This description includes only those items which are unique to input channels with Input Type = Master Comms. For other items please see section 4.3.3 of the User Guide supplied with this unit.

Channel Number	Allows the user to select the number of the channel to be configured. As soon as Modbus master is selected as input type, the display changes from 'Channel 1' (for example) to 'Read 1'. This legend stays as 'Read 1' 'until a descriptor is entered (below), which immediately overwrites it.
Slave	Allows the user to select (from a picklist), the slave from which data is to be retrieved. The picklist contains all the Remote Devices configured as slaves in the Master Comms Configuration described in section 3.2 , above.
Digital Parameter	Allows data to be read into a digital input - see section 3.3.4 . Allows the user to select Alarm setpoints, Process Value, Batch status (model dependent) or 'User defined' to be selected. 'User defined' allows a (decimal) register address to be entered (see section 3.3.3 , below).
Scaling	For some slaves, scale zero (scale low) is returned as value 0 and full scale (scale high) as value 65,535 (Hex FFFF) with intermediate values having proportionate values. For example the value 15, would be represented as 32,767 (7FFF) for a channel scale 0 to 30, as would a value of 50 for a channel scaled 0 to 100, and a value of 45 for a channel scaled 30 to 60. In order to convert this reading to an understandable value, a scaling factor must be entered. If the low and high scale entries match the slave channel's scale, the master reading will be the same as the slave's reading. Selecting 'High/Low' allows Scale low and Scale high values to be entered for the selected parameter. If 'None' is selected, the process value is displayed as a proportion of 64k.
Point type	This item appears for Alarm setpoints and Process Value parameters only. Point type allows the relevant point type (i.e. input channel, maths channel, totaliser etc.) in the slave to be selected.
Point number	This item appears for Alarm setpoints and Process Value parameters only. Point number allows the relevant point number in the slave to be selected.
Group Number	This item appears for Parameter = 'Batch Status' only. Group number allows that group, the status of which is to be read, to be defined.
Process Value	Allows one of three rates to be set for reading the Process Value. The three rates (Low, Medium and High) have the values set in the Master Comms configuration (section 3.2).
Span	Where the input value is scaled (see above), this 'Span' setting sets the Zero and Full Scale values for the channel. This is different from the situation obtaining in input channels, where span and scale have different meanings.

Remaining items are as described in Channel Configuration in section 4.3.3 of the User Guide supplied with this unit.

3.3.2 Controller parameters

The following parameters may be accessible from a controller, depending on type.

Note: Figure 3.2.2 is a typical page and may show more or fewer items than appear on the actual screen for a particular controller

Channel Number 1) Read 1 ▼ ← Reflects descriptor entry

Value -0.4670 Unadjusted

Input Type Master Comms ▼

Slave 1) Furn 1 Control ▼ ← Select Required slave

Digital

Parameter Working Setpoint ▼ ← Select Required slave parameter

Loop Number 1 ← Select required loop

Process Value Medium Priority ▼ ← Select iteration rate for parameter update

PV Format Numeric ▼

Span Low 0 Units

Span High 1 Units

Zone Low 0 %

Zone High 100 %

Max Decimal Digits 4

Colour

Units Units

Descriptor Read 1

Alarm Number 1

Enable Trigger ▼

Apply Discard

Figure 3.3.2 Typical Controller parameter page

3.3.2 CONTROLLER PARAMETERS (Cont.)

TYPICAL CONTROLLER PARAMETERS

Channel Number	Allows the user to select the number of the channel to be configured. As soon as Modbus Master is selected as input type, this changes from 'Channel 1' (for example) to 'Read 1'. Once communication with the slave is established, this will change to the descriptor of the remote channel (unless the controller type does not support this item, in which case a suitable descriptor can be entered later in the configuration).
Slave	Allows the user to select (from a picklist), the slave from which data is to be retrieved. The picklist contains all the Remote Devices configured as slaves in the Master Comms Configuration described in section 3.2 , above.
Digital Parameter	Allows data to be read into a digital input - see section 3.3.4 . Allows the user to select a specific parameter (table 3.3.1 shows a typical set) or 'User defined' to be selected. 'User defined' allows a (decimal) register address to be entered (see 'User defined', below).
Loop number	Allows the user to enter a Loop Number for the parameter read.
Process Value	Allows one of three rates to be set for reading the Process Value. The three rates (Low, Medium and High) have the values set in the Master Comms configuration (section 3.2).
Span Zone etc.	This 'Span' setting allows the Zero and Full Scale values for the parameter to be entered. The remaining items are as described in Channel Configuration in section 4.3.3 of the User Guide supplied with this unit.

Alarm status
Auto/Manual
Process value
Read alarm active status
Read alarm unacknowledged status
Working output power
Working setpoint

Table 3.3.1 Typical Controller read parameters

3.3.3 User defined registers

As previously mentioned, 'User Defined' can be selected for all slaves, and for some slave types, it is the only way of accessing some or all parameters.

The number of the register holding the required parameter is to be found in the user documentation supplied with the slave. For instance, if the unit to which this manual refers, were to be a slave, then the list of registers is to be found in section 2, above. For example, for this instrument, to determine what type of alarm, alarm 1 on channel 2 is, register 396 would be used, and the expected value would be 0 for Absolute low, 1 for absolute high, 2 for Deviation in, 3 for Deviation out, 4 for Rate-of-change high or 5 for Rate-of-Change low.

Channel Number ← Reflects descriptor, once the Apply key has been operated.

Value Unadjusted

Input Type

Slave ← Select required slave

Digital

Parameter ← Select required slave parameter

Function Code ← Select Function Code

Register ← Enter required register number (decimal)

Data Type ← Select Data Type

Scaling ← Select 'None' or 'Decimal Places'

Decimal Places ← Enter No. of decimal point shifts

Process Value ← Select iteration rate for continuous parameters

PV Format

Span Low Units

Span High Units

Zone Low %

Zone High %

Max Decimal digi

Figure 3.3.3 Configuration page for user defined parameters

CONFIGURABLE PARAMETERS

This section defines those parameters which are unique to user defined registers.

Value	Shows the value returned from the selected register, as modified by the scaling factor (if any).
Function Code	Allows Modbus function code 03 or 04 to be selected. In some implementations, the functions of the two codes are identical. In others, the codes have different functions. See the documentation supplied with the slave for a list of supported Modbus codes. For this instrument see section 2.2.1 .
Register	A decimal number representing the required parameter's location in the slave's Modbus Register map. This information must be determined from the documentation supplied with the slave. For this instrument, section 2.4 contains listings for a number of instrument, groups, and input channels. For details of maths, totalisers etc., refer to the relevant option description.
Data Type	Select a suitable data type for the selected parameter (again from the slave documentation). For this instrument, a list of relevant data types is given in section 2.4 .

3.3.3 USER DEFINED REGISTERS (Cont.)

CONFIGURABLE PARAMETERS (Cont.)

Scaling

Whether Scaling appears or not is Model and Parameter dependent. If scaling is required, the choice may be 'Decimal Places, or High/Low, again according to Model.

'Decimal Places' allows a dividing factor to be entered. An entry of 1, divides the returned value by 10. An entry of 2, divides by 100 etc. for successful implementation, there must be a sufficient number of decimal places defined in the 'Max Decimal Digits' configuration field for the value to be displayed with the required precision.. 'None' leaves the returned value unchanged. 'None' leaves the returned value unchanged.

For some slaves, scale zero (scale low) is returned as value 0 and full scale (scale high) as value 65,535 (Hex FFFF) with intermediate values having proportionate values. For example the value 15, would be represented as 32,767 (7FFF) for a channel scale 0 to 30, as would a value of 50 for a channel scaled 0 to 100, and a value of 45 for a channel scaled 30 to 60. In order to convert this reading to an understandable value, a scaling factor must be entered. If the low and high scale entries match the slave channel's scale, the master reading will be the same as the slave's reading. Selecting 'High/Low' allows Scale low and Scale high values to be entered for the selected parameter. If 'None' is selected, the process value is displayed as a proportion of 64k.

3.3.4 Reading digital values

Digital values can either be the open/closed status of a discrete input, or it can be a status string showing, for example Instrument Status, if 'User Defined' is selected as Parameter Type,

OPEN/CLOSED STRINGS

The text strings for the open and closed statuses of a digital input channel can be read by 'Enabling' the Digital checkbox for the relevant slave and Channel number. The strings returned will be those entered in the slave channel's configuration.

The default values are representations of an open switch (for Open) and a closed switch (for Closed). Figure 3.3.4a shows these two states.

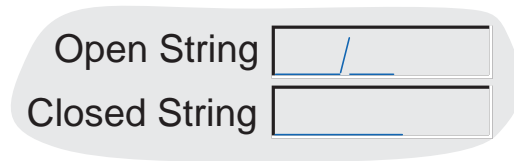

Figure 3.3.4a Default Open/Closed depictions

STATUS BITS

This allows the user to view the value of a bit in a status word such as Instrument Status, Channels in Group etc. The relevant Register is accessed by entering its decimal number into the Register field which appears when 'User Defined' is selected as Parameter.

Example

Figure 3.3.4b, below shows a master channel configuration page which causes a message* to be sent to group 1 if the floppy disk inserted in a slave recorder (of the same type as that described by this manual) is worn. Open / closed strings are also entered as Disk OK and Disk Worn respectively, so that if this channel is included in a group, then whichever of these legends is appropriate will be displayed in the channel faceplate.

* Note: The message string is entered as a part of Message Configuration as described in section 4.3 of the User Guide.

For this instrument, type, Instrument Status is held at register number 22. As can be seen from the table in [section 2.4.1](#), above, the bit allocation is as shown (reformatted) in table 3.3.4. From this table, it can be seen that bit 2 status is related to whether the disk is worn or not.

Bit	Item being tested	Status		Value
0	Real time clock.	0 = OK	1 = Fail	1
1	Floppy Disk.	0 = OK	1 = Worn	2
2	Card/Disk.	0 = OK	1 = Corrupt	4
3	Card/Disk.	0 = Inserted	1 = Missing	8
4	Card/Disk	0 = Not full	1 = Full	16
5	System history partition.	0 = Healthy	1 = Failed	32
6	Data recording engine.	0 = Healthy	1 = Failed	64
7	Channel status.	0 = No failures	1 = Channel failure	128

Table 3.3.4 Instrument status (Register 22)

3.3.4 READING DIGITAL VALUES EXAMPLE (Cont.)

Channel Number	1) Disk Wear ▼
Value	OK
Input Type	Master Comms▼
Slave	1) Recorder ▼
Digital	<input checked="" type="checkbox"/>
Parameter	User Defined ▼
Function Code	Read input registers (4) ▼
Register	22
Data Type	Bit (from register) ▼
Bit Position	2
Process Value	Medium Priority▼
Zone Low	0 %
Zone High	100 %
Colour	0
Open String	OK
Closed String	DiskWorn
Descriptor	Disk Wear
Alarm Number	1▼
Enable	Trigger ▼
Type	Digital▼
Active when	DiskWorn▼
Dwell	0 s
Job Number	1▼
Category	Message ▼
Send message(s) to	Group ▼
Group	1) Group 1▼
First Message	1) Disk Worn ▼
Last Message	1) Disk Worn ▼
On	Active ▼
<input type="button" value="Apply"/> <input type="button" value="Discard"/>	

Figure 3.3.4 Example configuration page

3.4 DEMAND WRITE CONFIGURATION

Demand writes allow slave values to be written acyclically from the master, by operator action from the configuration page, by job action, or (if the User Screens option is fitted) by operation of a suitably configured Operator key. Figure 3.4 shows a typical configuration page. Modbus codes 6 and 16 can be selected for this purpose - see section 2.2.1 for code definitions.

Figure 3.4.1a shows a typical configuration page, for writing to a recorder. Figure 3.4.1b shows the Edit Constant page. Figure 3.4.2 shows a configuration page for the case where the destination is defined as a register location.

3.4.1 Writing to a known recorder

Figure 3.4.1a shows the configuration page for writing a value from the master unit to a 'known' slave unit.

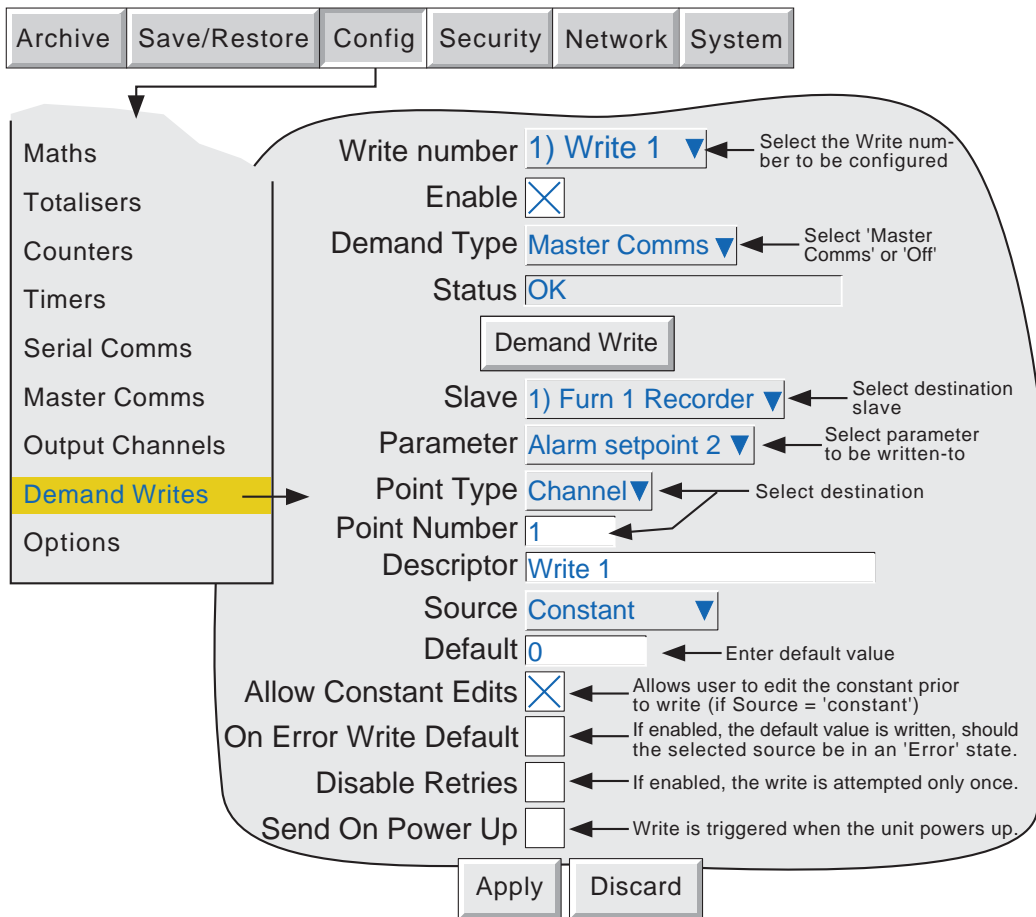

Figure 3.4.1a Typical Demand write configuration page

3.4.1 WRITING TO A REMOTE RECORDER (Cont.)

CONFIGURABLE ITEMS

Write number	Allows the user to select the Demand Write number to be configured
Enable	Allows the user to enable/disable the write.
Demand Type	Select 'Master Comms' or 'Off'
Status	Shows the status of the transaction. The meaning of most status strings are self-evident, the remaining ones have the following definitions: OK: Transaction was carried out and a satisfactory response has been received Idle: Appears only before the first Write following a power cycle, or if the Write has not previously been configured. Pending: Appears if the Write is waiting to happen, or a response is being waited for. Can appear, for example, if the Write is queued. Timeout: Appears if the slave fails to respond within the timeout set in the Master Comms configuration page. Transaction Disabled: Appears, for example, if the Write has been disabled, but a job is still trying to trigger it.
Slave	Allows the user to select the Slave to be written-to, from a picklist containing all the configured devices in the Master Comms configuration page.
Parameter	Select parameter to be written to (picklist varies according to slave type/model)
Point type/Loop Number/Group Number	Allows a point, loop or group number to be entered for the selected parameter.
Descriptor	Allows a descriptor to be entered for the Write.
Source	Allows the source of the Write to be chosen, from a picklist containing 'Constant' plus all points in the recorder.
Default	Allows a value to be entered for use as a default to be written to the destination point. Appears if 'Source' = 'Constant', or for any other source, if the 'On Error Write Default' checkbox (see below) is enabled.
Allow Constant edits	If this is enabled, the user may change the default value before it is sent. Applies only to user-triggered writes. See 'Demand Write Button', below.
On Error Write Default	If this function is enabled, then the default value is written, instead of the source value, should the source be in an Error state. When enabled, the 'Default' entry box appears, if it was previously hidden.
Disable Retries	If enabled, this function causes the recorder to attempt the Write only once, instead of retrying according to the number of retries set in the Master Comms Configuration Page.
Send On Power Up	If enabled, this causes the default value to be Written at Power-Up.

DEMAND WRITE BUTTON

When operated, this pushbutton causes the Write to be initiated. If the source is 'Constant' and the 'Allow Constant Edits' item is enabled, an 'Edit' page appears (figure 3.4.1b) allowing the user to change the constant value from its default value, before the Write is carried out. Otherwise, the Write is carried out without any further action being required.

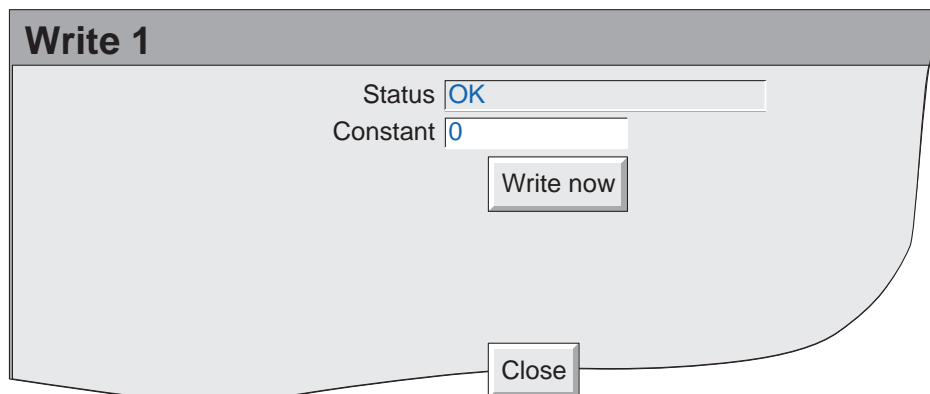

Figure 3.4.1b Constant Edit page

3.4.2 Writing to a specific register

When 'User Defined' is selected, or if the slave device is 'Unknown', then a register can be defined which can be written-to directly. The register addresses must be found from the documentation supplied with the slave device.

The screenshot shows a configuration window for 'Demand Write'. At the top, there's a 'Write number' dropdown set to '1) Write 1' with an arrow pointing to it from the text 'Select the Write to be configured'. Below it is an 'Enable' checkbox that is checked. The 'Demand Type' is set to 'Master Comms' with an arrow pointing to it from 'Select 'Master Comms' or 'Off''. The 'Status' is 'Idle'. A 'Demand Write' button is centered. Below that, the 'Slave' is '1) Furn 1 Recorder' with an arrow pointing to it from 'Select destination slave'. The 'Parameter' is 'User Defined'. The 'Function Code' is 'Preset Multiple Register (16)'. The 'Register' is '248'. The 'Data Type' is 'Float (32 Bit)'. The 'Descriptor' is 'Write 1'. The 'Source' is 'Constant'. The 'Default' is '0' with an arrow pointing to it from 'Enter default value'. There are four checkboxes: 'Allow Constant Edits' (checked, with arrow from 'Allows user to edit the constant prior to write (if Source = 'constant')'), 'On Error Write Default' (unchecked, with arrow from 'If enabled, the default value is written, should the selected source be in an 'Error' state.'), 'Disable Retries' (unchecked, with arrow from 'If enabled, the write is attempted only once.'), and 'Send On Power Up' (unchecked, with arrow from 'Write is triggered when the unit powers up.'). At the bottom are 'Apply' and 'Discard' buttons.

Figure 3.4.2 Demand Writes to specific register

CONFIGURABLE PARAMETERS

This contains details of parameters unique to Demand Writes to specific registers. Other parameters are described in [section 3.4.1](#), above.

- Function Code Allows the Modbus function code 6 or 16 to be selected. See the documentation supplied with the slave for a list of supported Modbus codes (for this instrument see [section 2.2.1](#)). Demand writes of a single 8 or 16-bit register can use either code, but code 6 is more efficient. Writing two or more registers requires the use of code 16.
- Register A decimal number representing the required parameter's location in the slave's Modbus Register map. This information must be determined from the documentation supplied with the slave. For this instrument, [section 2.4](#) contains listings for a number of instrument, groups, and input channels. For details of maths, totalisers etc., refer to the relevant option description.
- Data Type Select a suitable data type for the selected parameter (again from the slave documentation). For this instrument, a list of relevant data types is given in [section 2.4](#).

3.4.2 WRITING TO A SPECIFIC REGISTER(Cont.)

CONFIGURABLE PARAMETERS (Cont.)

Scaling Whether Scaling appears or not is Model and Parameter dependent. If scaling is required, the choice may be 'Decimal Places, or High/Low, again according to Model.

'Decimal Places' allows a dividing factor to be entered. An entry of 1, divides the returned value by 10. An entry of 2, divides by 100 etc. for successful implementation, there must be a sufficient number of decimal places defined in the 'Max Decimal Digits' configuration field for the value to be displayed with the required precision.. 'None' leaves the returned value unchanged. 'None' leaves the returned value unchanged.

For some slaves, scale zero (scale low) is returned as value 0 and full scale (scale high) as value 65,535 (Hex FFFF) with intermediate values having proportionate values. For example the value 15, would be represented as 32,767 (7FFF) for a channel scale 0 to 30, as would a value of 50 for a channel scaled 0 to 100, and a value of 45 for a channel scaled 30 to 60. In order to convert this reading to an understandable value, a scaling factor must be entered. If the low and high scale entries match the slave channel's scale, the master reading will be the same as the slave's reading. Selecting 'High/Low' allows Scale low and Scale high values to be entered for the selected parameter. If 'None' is selected, the process value is displayed as a proportion of 64k.

DEMAND WRITES WITH AUDIT TRAIL

Normal Audit Trail messages include both the new value and the previous value, for example

24/06/03 11:27:58 1) Temp1 Alarm Number 1 Enable **Latched was Off**

With Demand Writes, the recorder has no way of determining what the value, of the parameter being written to, was prior to the Write. For this reason no 'was' value is included in the message. A typical Demand Write audit trail message would be:

24/06/03 11:35:10 Write_1 wrote 255.75

Please see section 4.4.2 of the user guide for more details of Audit Trail.

3.5 OUTPUT CHANNELS

This is included in the Master Comms section because the feature allows a master Unit to write one (or more) of its points to one (or more) slaves' channels. The Analogue output (retransmission) hardware option, which allows an input channel to be mapped to a physical output channel is described in the options manual.

Figure 3.5 shows a typical configuration page.

3.5.1 Configurable parameters

Output Channel Number	Allows the user to select the Output to be configured.
Enable	Allows the output channel to be enabled or disabled.
Output Type	Select Master Comms for this functionality
Slave	Select the slave to be written-to.
Parameter	Select required parameter from picklist (varies according to slave type/model)
Scaling	If this field appears (depends on slave type), the Low and High scaling should match that of the slave Channel being written to.
Point Type	Allows a point type to be chosen from a picklist. (Picklist items vary according to slave type/model)
Point Number	For recorders, allows a point number to be entered. This point must be configured as 'Comms' or 'Slave Comms' etc. (depending on slave type or model) at the slave.
Loop Number	For Controllers, allows a loop number to be selected form a picklist.
Process Value	Allows the selection of High, Medium or Low priority interval, as defined in the Master Comms configuration page (section 3.2).
Descriptor	Allows a descriptor of up to 20 characters to be entered for the output channel name.
Source	This allows the user to select the source point to be written to the slave destination point.
Default	This is the value written, if the source is in 'Error', and the 'On error Write Default' item (below) has been enabled.
On Error Write Default	If this item is enabled, the default value is written instead of the selected Source, if the Source is in 'Error'.

3.6 MASTER COMMS CHANNEL CONFIGURATION EXAMPLE

This example describes a recorder (Furn1 Master) acting as a master to two other recorders (Furn1 Record and Furn2 Record) and a controller (Furn1 Control). This example shows only the configuration pages necessary to set up the master input/output channels and the slave Comms channel. It is assumed that:

- a. the master comms configuration has been completed with Remote devices 1, 2 and 3 set up as Furn1 Control, Furn1 Record and Furn2 control, respectively.
- b. all recorders are of the type described in this manual. Other types of slave may need more inputs, or different inputs to be entered.

3.6.1 Example

As depicted in figure 3.6.1, to:

Read Loop1 PV from Controller 1 to Channel 1 of Recorder 1 (the master)

Read Channel 1 from Recorder 2 to Channel 2 of the master

Write Channel 2 of the Master to Channel 1 of Recorder 3.

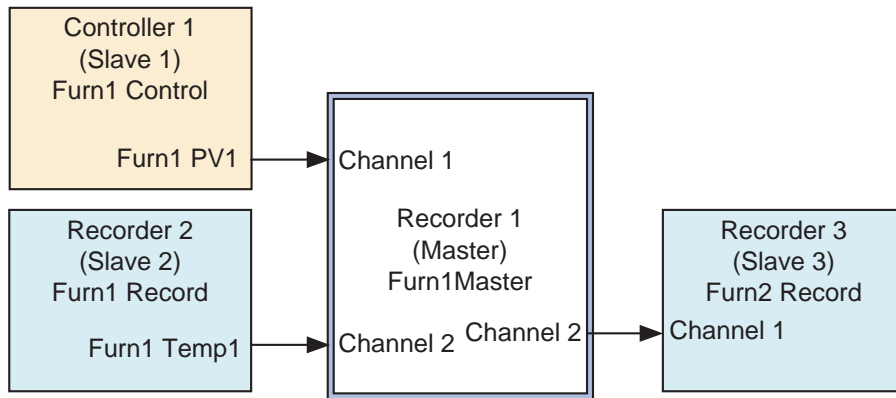

Figure 3.6.1 Required setup

3.6.2 Master channel 1 setup

Master channel 1 setup, to read the Loop1 PV from 'Furn1 Control' into channel 1, is shown in figure 3.6.2, below. Note that, for this example that a Span High of 100 and Descriptor 'Furn1 PV1' have been entered. The span zero and span high values should match those of the PV being read.

Channel Number 1) Furn1 PV1 ▾

Value 33.2453 Unadjusted

Input Type Master Comms ▾

Slave 1) Furn1 Control ▾

Digital

Parameter Process Value ▾

Loop Number 1

Process Value Medium Priority ▾

PV Format Numeric ▾

Span Low 0 Units

Span High 100 Units

Zone Low 0 %

Zone High 100 %

Max Decimal Digits 4

Colour █

Units Units

Descriptor Furn1 PV1

Configuration Data Low Priority ▾

Alarm Number 1

Enable Trigger ▾

Apply Discard

Figure 3.6.2 Master Channel 1 setup example

3.6.3 Master channel 2 setup

Master channel 2 setup, to read the Channel 1 PV from 'Furn1 record into channel 2', is shown in figure 3.6.3, below.

Channel Number 2) Furn1 Temp1 ▾
 Value 658.3654 Unadjusted
 Input Type Master Comms ▾
 Slave 2) Furn1 Record ▾
 Digital
 Parameter Process Value ▾
 Point Type Channel ▾
 Point Number 1
 Process Value Medium Priority ▾
 PV Format Numeric ▾
 Span Low 0 Units
 Span High 1000 Units
 Zone Low 0 %
 Zone High 100 %
 Max Decimal Digits 4
 Colour 0
 Units Units
 Descriptor Furn1 Temp 1
 Configuration Data Low Priority ▾
 Alarm Number 1
 Enable
 Apply Discard

Figure 3.6.3 Master Channel 2 setup example

3.6.4 Master Output 1 setup

This shows the setup required in order to output the master's channel 2 (Furn1 Temp1) to Furn2 Record channel 1. The Descriptor Furn1 Temp1 has been entered as the Output Name. This happens to be the same as the channel descriptor, but could be any required text string.

Output Channel Number 1) Furn1 Temp 1
 Enable
 Output Type Master Comms
 Slave 3) Furn2 Record
 Parameter Comms Channel
 Point Type Channel
 Point Number 1
 Process Value Medium Priority
 Descriptor Furn1 PV1
 Source 2) Furn1 Temp1
 Default 0
 On Error Write Default
 Apply Discard

Figure 3.6.4 Master Output 1 setup example

3.6.5 Slave Input Channel 1 setup

Figure 3.6.5 shows how to set up a slave channel to read an input from a master. Note that the scaling of this channel must match the scaling of the source channel.

Channel Number 1) Furn1 Temp1
 Value 658.3654 Unadjusted
 Input Type Slave Comms
 Slave 2) Furn1 Record
 Scale Low 0 Deg C
 Scale High 1000 Deg C
 Units Deg C
 Scale Type Linear
 Scale Divisions - Major 10
 Scale Divisions Minor 1
 Descriptor Furn1 Temp 1
 Apply Discard

Figure 3.6.5 Slave channel setup

3.7 MASTER COMMS DIAGNOSTICS

Master Comms Diagnostics appears as an additional item on the System Menu. For details of the other items see the User Guide supplied with this unit.

Most items are self-evident.

The Total requests and Bad requests totals both exclude retries. The numbers in parentheses are error message numbers.

The Initiate Comms Test is a loop-back test that sends a message to the selected slave and waits for it to be returned. If the test is successful, the 'Successful Comms Test' is incremented. If not successful, one (or more) of the error box values is incremented.

Figure 3.7 shows a typical page.

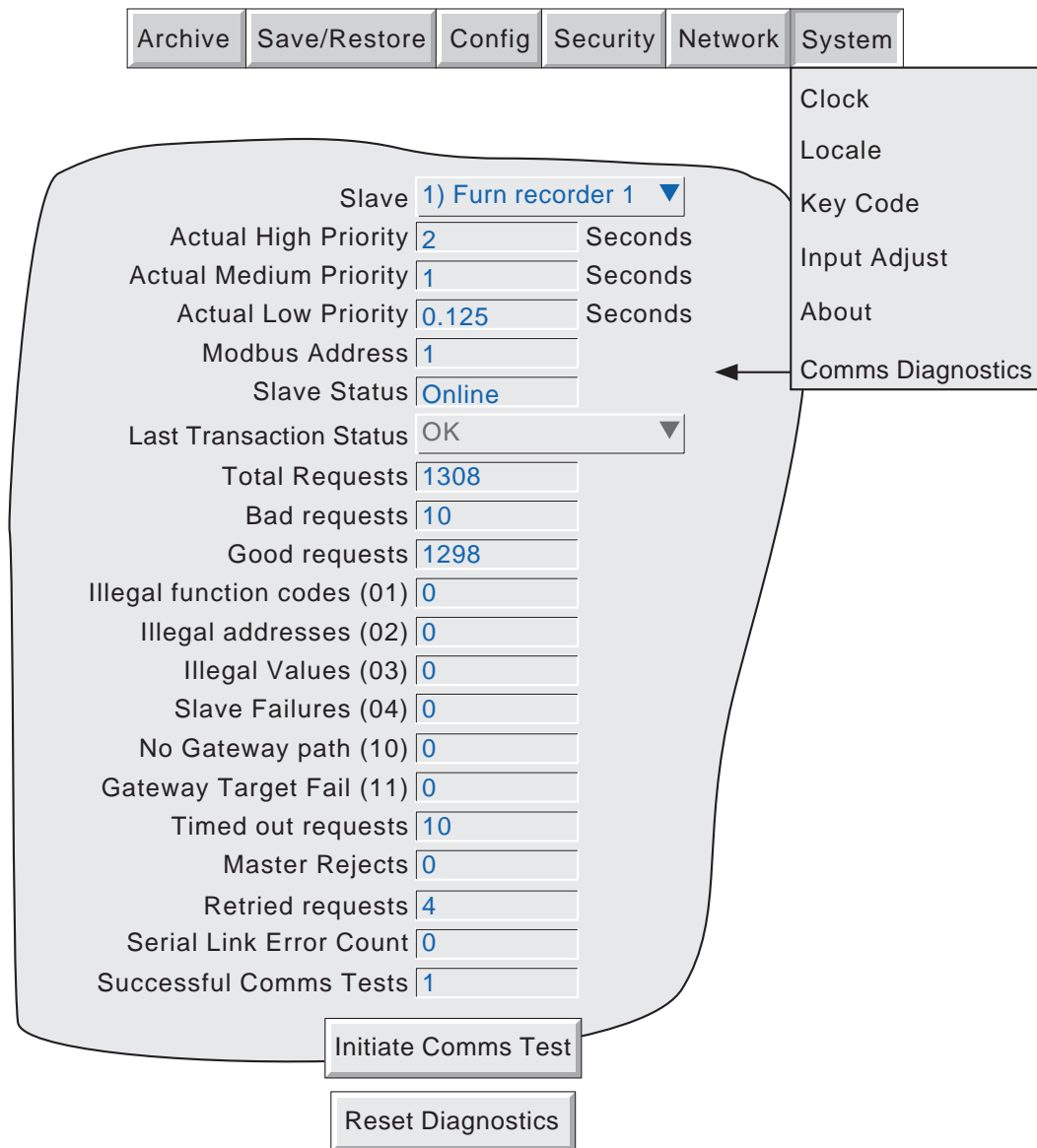

Figure 3.7 Master Comms diagnostic page

4 SERIAL COMMUNICATIONS OPTION

4.1 INTRODUCTION

4.1.1 ASCII

This mode allows the recorder to receive simple ASCII messages from, for example, barcode readers, Programmable Logic Controllers (PLCs), Global Positioning Systems (GPSs) (NMEA-0183 protocol) etc. Messages are sent to as many groups as are set up to receive them, and become a part of these groups' histories, and appear on vertical and horizontal trend displays in the following format:

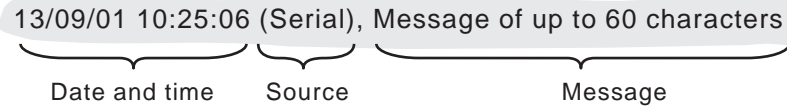

4.1.2 MODBUS RTU

This allows the recorder's serial communications 'port' to be used as Modbus master or Modbus slave. When acting as a master, the unit can communicate with up to 16 slaves. Use of the Serial port is complementary to the use of Ethernet connections.

Note: When configuring a unit as a Modbus slave, it is recommended that the Instrument and Point Configurations give easily identifiable instrument and point names (descriptors).

4.2 INSTALLATION

The communications standard is either EIA232 OR EIA485 as specified at time of order. Figure 4.2 gives the alternative pinouts. Changing from one standard to the other is a non-trivial task - please refer to the local sales office for information.

Note: To reduce the effects of Radio Frequency Interference (RFI), it is recommended that twisted pair, screened, communications cable be used for wiring the serial link. Each length of screen must be connected to earth but, in order to avoid potentially hazardous circulating currents, it may be earthed at one point only.

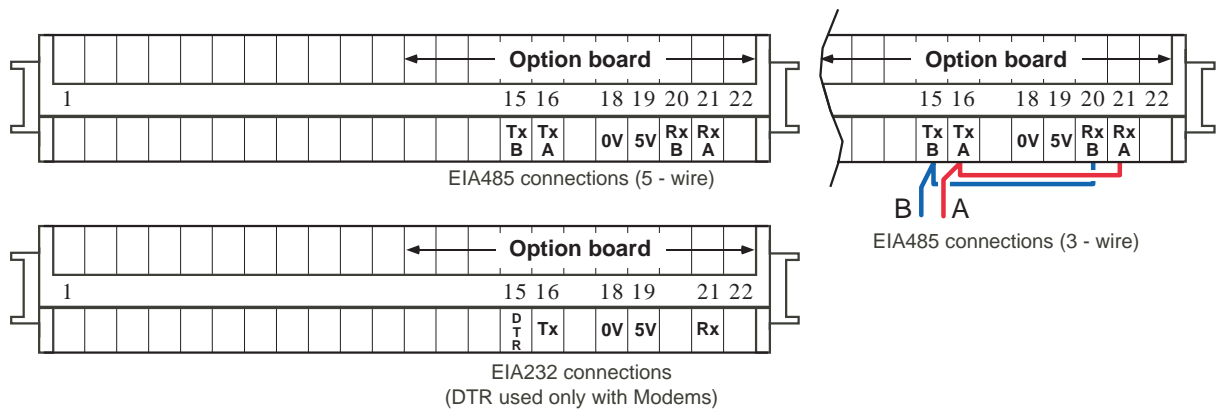

Figure 4.2 Comms board pinout

4.2.1 Installation rules:

1. Other options (e.g. relay outputs, TRS) must occupy lowest slot numbers
2. Comms may be fitted only in even numbered slots (except 180 mm units, where the comms board may be located in slot 9 as an alternative).

4.2.2 Termination and biasing (Not EIA232)

If the communications line is left open-ended, the end of the cable acts as a reflector, returning what can appear to be 'true' data signals back down the line. A receiver cannot distinguish between 'true' and reflected data, with the result that the 'true' data is corrupted.

In order to avoid this, a termination resistor is fitted across the line at the final instrument. If the value of this resistor is equal to the characteristic impedance of the cable (e.g.120 Ohms), then the line appears to be of infinite length and no reflections occur. Such a value however, does not always give the best signal-to-noise ratio, so a compromise value (e.g. 220 Ohms) is normally selected to give the optimum performance in reducing unwanted reflections and in improving the signal-to-noise ratio. The recorder communications port is terminated as shown in figure 4.2.2, below, for a single point-to-point application.

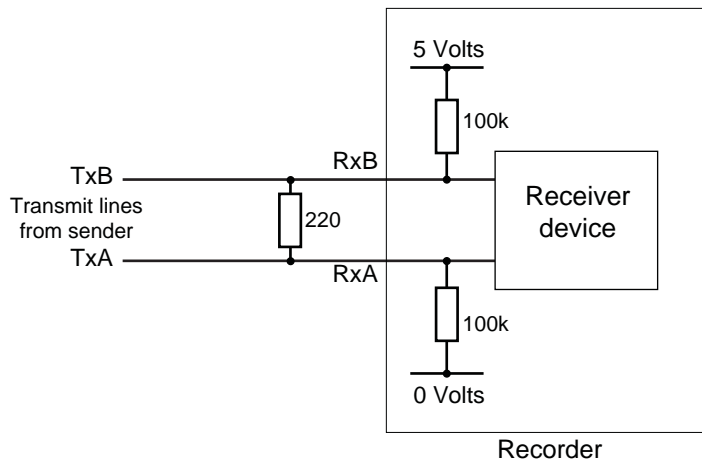

Figure 4.2.2 Recorder termination (single-drop EIA485 application)

4.3 CONFIGURATION

The default (ASCII) Serial comms configuration menu is as shown in figure 4.3a below. Figures 4.3b and 4.3c show the alternative menus for Modbus slave and Modbus master selections, respectively.

Note: The serial communications hardware is limited to one start bit.

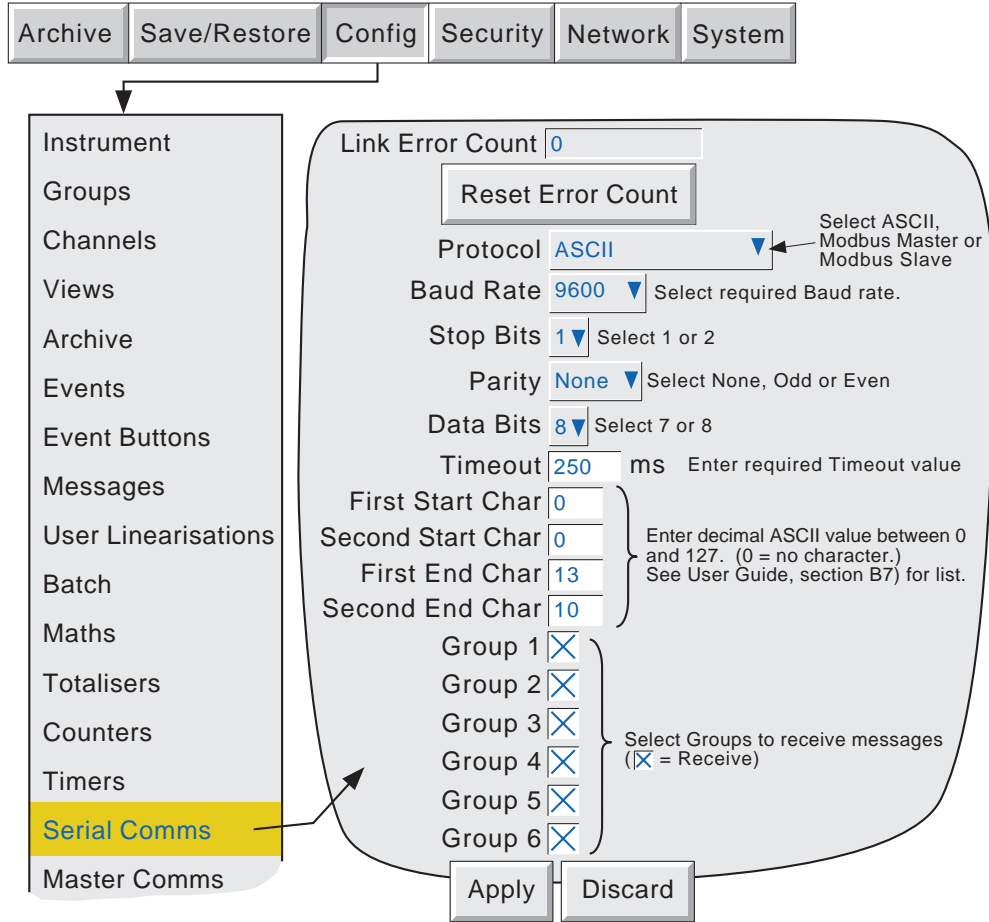

Figure 4.3a Serial Communications configuration menu (ASCII)

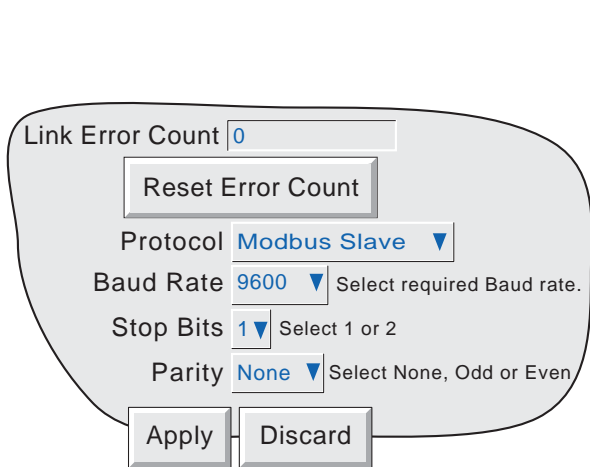

Figure 4.3b

Serial Communications configuration menu (Modbus slave)

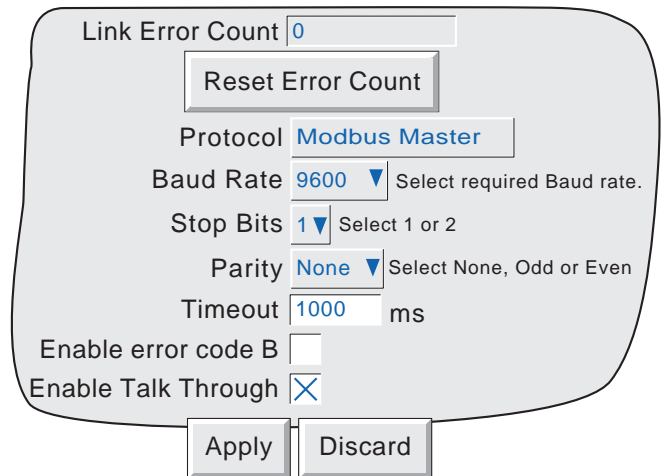

Figure 4.3c

Serial Communications configuration menu (Modbus master)

4.3.1 Configuration parameters

LINK ERROR COUNT

A Link error count is provided for every slave. The count is incremented every time there is a framing error, a parity error or a Cyclic redundancy check (CRC) error. The 'Reset Error Count' key is used to reset the count to zero.

PROTOCOL

Select ASCII , Modbus slave or Modbus master.

BAUD RATE

Allows a Baud rate to be chosen from a picklist of: 300, 600, 1200, 4800, 9600, 19200, 38400. This value must be the same for all devices in the serial link.

STOP BITS

Selectable as 1 or 2. This value must be the same for all devices in the serial link.

PARITY

Allows Parity to be chosen from a pick list of: None, Odd, Even. This value must be the same for all devices in the serial link.

DATA BITS

For ASCII protocol only, selectable as 7 or 8. This value must be the same for all devices in the serial link.

TIMEOUT

For ASCII protocol, this allows a timeout value to be entered of between 50 and 3000 msec inclusive. A value of 0 = no timeout. See section 4.4, below.

For Modbus Master protocol, this allows a timeout to be entered of between 100 and 9,999 msec (inclusive), An error code B is generated (if so configured - see 'Enable Error Code B' below.) if the master has not received a reply to a request within the timeout period. For slaves configured with their own timeout periods, these will override the entry here.

MESSAGE START/END CHARACTERS

For ASCII protocol only

The message can be prefixed by 0, 1 or 2 specific characters and can be suffixed by 0, 1 or 2 specific characters. The First and Second Start and End characters are entered as decimal ASCII codes between 0 and 127 as required. 0 = no character, 10 = Line Feed; 13 = Carriage Return. See Annex B to the User Guide supplied with this unit, for a list of ASCII codes. If only one start or end character is required, the first character must be entered, and the second character be entered as zero.

GROUP SELECTION

For ASCII protocol only.

Allows groups to be deselected/selected for receipt of the messages. A checked box indicates that the associated group will receive the messages.

ENABLE ERROR CODE B

For Modbus Master only.

If enabled, this causes an error code B to be generated in the event of a timeout or a Cyclic Redundancy Check (CRC) error.

4.3.1 CONFIGURATION PARAMETERS (Cont.)

ENABLE TALK THROUGH

For Modbus Master only.

If enabled, this prevents 'external' (Ethernet) masters from accessing the slaves connected to this instrument. (I.E. only this instrument can act as a master to its slaves.)

4.4 MESSAGING INFORMATION

Characters are read into a buffer, until the end of message characters are received, or until the time-since-last-character exceeds the entered Timeout value. Date, Time and '(Serial)' are then prefixed to the message, which is then sent to the selected groups. The date and time relate to when the first buffered character was received. If Start-of-message characters are configured, characters will be read into the buffer only after these characters have been received.

The buffer holds up to 60 characters. Further characters are discarded until End-of-message is received, or timeout occurs. These 60 characters do not include date/time etc. or start/end-of-message characters

Message characters below Hex 20 (decimal 32) will be replaced by question marks (?).

Message characters above Hex 7F (decimal 127) will be treated as Unicode.

4.4.1 Messaging Rules

- 1 If no start-of-message characters are configured, but a timeout value other than 0 has been entered, the new message will start after the timeout period has elapsed.
- 2 If no end-of-message characters are configured, but a timeout value other than 0 has been entered, the new message will end after the timeout period has elapsed.
- 3 If start-of-message characters are configured, and a timeout value other than 0 has been entered, all characters prior to the Start-of-message characters are ignored.
- 4 If start-of-message are configured but neither end characters nor timeout have been configured, then this is an invalid configuration.
Should this configuration be a requirement, if the same characters are entered as end-of-message characters instead, then each message will be sent to the groups when the next message is received.
- 5 If no start or end-of-message characters are entered and no timeout value is entered, all received characters are discarded
- 6 If a received message is deemed to be corrupt, it is discarded and the software will await a further message.
- 7 Start and End-of-message characters are removed before the messages are sent to the groups.

INDEX

A

Address
 Allocation (MODBUS) 25
 Map (MODBUS) 23
 Allow Constant edits 81
 ASCII 90
 Audit trail 83

B

Baud Rate (Serial comms) 93

C

Channel
 Configuration
 32-bit data (MODBUS) 53–63
 MODBUS 26–51
 Run-time data
 32-bit (MODBUS) 57–63
 Run-time data (MODBUS) 38–51
 Comms
 Modbus master 67
 Serial 90
 Config. data update rate 73, 75
 Configuration
 Master comms 68
 Serial Communications 92
 Controller parameters 75

D

Data
 Bits (Serial comms) 93
 Encoding (MODBUS) 16
 Transmission (MODBUS) 63
 Type 16, 76, 82
 Default
 Demand Write 81
 Output channel 84
 Demand
 Type 81
 Write 80
 Button 81
 With Audit Trail selected 83
 Descriptor
 Modbus slave 69
 Detect this slave/all slaves 69
 Digital 73, 75
 Disable retries 81

E

Enable
 Demand Write 81
 Error Count B 93
 Modbus slave 69
 End of message characters 93
 Error messages (Remote Viewer) 14
 Ethernet Modbus slave 69

F

Failed to authenticate user name 14
 Feature
 Changed 7
 Identification table 50
 Locked 7
 First Start/End Char 93
 Function code 76, 82
 Function code 03 (MODBUS) 64
 Function code 04 (MODBUS) 65
 Function code 06 (MODBUS) 65
 Function code 08 (MODBUS) 65
 Function code 16 (MODBUS) 66

G

Group
 Data (MODBUS) 44
 Number 73
 Selection for comms messages 93

H

High Priority interval 68

I

Indirection tables (MODBUS) 50
 Instrument data (MODBUS) 25
 Invalid multiple register writes 16
 IP Address, Modbus slave 69

L

Link error count 93
 Login Required (Modbus slave) 69
 Long messages 21
 Loop number 75, 81, 84
 Low Priority interval 68

M

Master Comms 67–89
 Diagnostics 89
 Example configuration 85
 Maximum
 Block size 69
 Remote viewers 14
 Medium Priority interval 68
 Messages, Serial Comms 90
 Minimum PC requirements 8
 Modbus
 Address 69
 RTU 90
 Security 16
 Slave
 Enable 69
 Online 69
 Selection 68
 Wiring 15

N

Network
 Connection has timed out 14
 Ethernet/Serial selection 69

O

On Error Write Default 81, 84
 Online (Modbus slave) 69
 Open/Closed strings 78
 Output
 Channel
 (Modbus) 84
 Enable 84
 Type 84

P

Parameter 73, 75, 81, 84
 Parity (Serial comms) 93
 Point
 Number 73
 Type 73, 81
 Type/Number 84
 Process Value update rate 73, 75, 84
 Profile (Modbus slave) 69
 Protocol (Serial comms) 93

R

Reading
 Digital values 78
 User defined registers 76
 Register 82
 Remote viewer
 Alarm acknowledgement 13
 Configuration
 Access menu 11
 Options menu 10
 Connection details 9
 Minimum PC requirements 8
 Operation 13
 Running the program 12
 Software installation 10
 Start as Lite 12
 Retry (Modbus slave) 69

S

Scaling 73, 76, 82, 84
 Second Start/End Char 93
 Security, Modbus 16
 Send on power up 81
 Serial (Modbus slave) 69
 Serial communications 90
 Message information 94
 Share socket 69, 71
 Slave 73, 75, 81, 84
 Slave selection 68
 Socket, share 71
 Source 81
 Output channel 84
 Span 73, 75
 Start
 as Lite 12
 Start/End characters 93
 Status
 Comms 81
 Stop bits (Serial comms) 93
 Store diagnostics 68

T

Termination and biasing 91
 Text messages (Modbus) 21
 There appears to be no free disk space... 7, 14
 Timeout
 Comms 93
 Modbus slave 69

U

Unable to connect to host 14
 Unable to resolve hostname 14
 User Defined 76

W

Wiring
 Modbus 15
 Serial Comms 90
 Serial comms 90
 Write
 Enable 81
 To register 82

Y

You are already running ... message 7, 14
 You are authenticating Full Remote Viewer... 7, 14

Z

Zone 75

Inter-Company sales and service locations

Australia

Eurotherm Pty. Limited.
Unit 10.
40 Brookhollow Avenue,
Baulkham Hills,
NSW 2153

Telephone: 61 2 9634 8444
Fax: 61 2 9634 8555
e-mail: eurotherm@eurotherm.com.au
<http://www.eurotherm.com.au>

Austria

Eurotherm GmbH
Geiereckstraße 18/1,
A1110 Wien,

Telephone: 43 1 798 76 01
Fax: 43 1 798 76 05
e-mail: eurotherm@eurotherm.at
<http://www.eurotherm.at>

Belgium and Luxemburg

Eurotherm S.A./N.V.
Rue du Val-Notre-Dame 384,
4520 Moha (Huy)
Belgium

Telephone: 32 (0) 85 274080
Fax: 32 (0) 85 274081
e-mail: sales@eurotherm-belgium.be
<http://www.eurotherm.nl>

Denmark

Eurotherm Danmark A/S
Finsensvej 86,
DK 2000 Fredriksberg,

Telephone: +45 (38) 871622
Fax: +45 (38) 872124
e-mail: salesdk@eurotherm.se

Finland

Eurotherm Finland,
Aurakatu 12A,
FIN-20100 Turku

Telephone: 358 2 25 06 030
Fax: 358 2 25 03 201

France

Eurotherm Automation Division Chessell
Parc d'Affaires,
6, Chemin des Joncs,
BP55

F - 69574 Dardilly, CEDEX
Telephone: 33 0 4 78 66 55 20
Fax: 33 0 4 78 66 55 35
e-mail: chessell@automation.eurotherm.co.uk
<http://www.eurotherm-chessell.fr>

Germany

Eurotherm Deutschland GmbH
Ottostraße 1,
65549 Limburg

Tel: +49 (0) 64 31/2 98 - 0
Fax: +49 (0) 64 31/2 98 - 1 19
e-mail: info@regler.eurotherm.co.uk
<http://www.eurotherm-deutschland.de>

Great Britain

Eurotherm Limited,
Faraday Close,
Worthing,
West Sussex BN13 3PL

Telephone: +44 (0)1903 695888
Fax: +44 (0)1903 695666
e-mail: Sales@recorders.eurotherm.co.uk
or: Support@recorders.eurotherm.co.uk
<http://www.eurotherm.co.uk>

Hong Kong

Eurotherm Limited,
Unit D, 18/F Gee Chang Hong Centre,
65, Wong Chuk Hang Road,
Aberdeen.

Telephone: 852 2873 3826
Fax: 852 2870 0148
e-mail: eurotherm@eurotherm.com.hk

India

Eurotherm DEL India Limited,
152, Developed Plots Estate,
Perungudi,
Chennai 600 096,

Telephone: 91 44 4961129
Fax: 91 44 4961831
e-mail: info@eurothermdel.com
<http://www.eurothermdel.com>

Italy

Eurotherm SpA,
Via XXIV Maggio,
I-22070 Guanzate,
Como.

Telephone: 39 031 975111
Fax: 39 031 977512
e-mail: info@eurotherm.it
<http://www.eurotherm.it>

Japan

Densei Lambda K.K.,
Strategic Products Dept.
5F Nissay Aroma Square,
37-1, Kamata, 5-Chome,
Ohta-ku,
Tokyo 144-8721

Telephone: 81 3 5714 0620
Fax: 81 3 5714 0621
e-mail (Sales): k.iwama@densai-lambda.com
e-mail (Technical): v.rendle@densai-lambda.com
<http://www.densei-lambda.com>

Korea

Eurotherm Korea Limited,
J- Building
402-3
Poongnab-Dong,
Songpa-Ku
Seoul, 138-040

Telephone: 82 2 478 8507
Fax: 82 2 488 8508

Netherlands

Eurotherm BV,
Genielaan 4,
2404CH Alphen aan den Rijn,
The Netherlands

Telephone: 31 172 411 752
Fax: 31 172 417 260
e-mail: Sales@eurotherm.nl
<http://www.eurotherm.nl>

Norway

Eurotherm A/S,
Vollsveien 13D
1366 Lysaker,
Postboks 227
NO-1326 Lysaker
Norway,

Telephone: 47 67 592170
Fax: 47 67 118301
<http://www.eurotherm.no>

Spain

Eurotherm España SA,
Pol. Ind. De Alcobendas,
Calle de la Granja 74,
28108 Alcobendas,
Madrid.

Telephone: 34 91 661 60 01
Fax: 34 91 661 90 93
<http://www.eurotherm.es>

Sweden

Eurotherm AB,
Lundavägen 143,
S-21224 Malmö.

Telephone: 46 40 38 45 00
Fax: 46 40 38 45 45
e-mail: info@eurotherm.se
<http://www.eurotherm.se>

Switzerland

Eurotherm Produkte (Schweiz) AG,
Schwerzistraße, 20,
CH-8807 Freienbach.

Telephone: 41 55 415 44 00
Fax: 41 55 415 44 15
e-mail: epsag@eurotherm.ch
<http://www.eurotherm.ch>

United States of America

Eurotherm Recorders Inc.
741-F Miller Drive
Leesburg
VA 20175-8993

Telephone: 1 703 669 1342
Fax: 1 703 669 1307
e-mail (Sales): sales@chessell.com
e-mail (Technical): support@chessell.com
<http://www.chessell.com>



invensys
EUROTHERM

EUROTHERM LIMITED

Faraday Close, Durrington, Worthing, West Sussex, BN13 3PL
Telephone: 01903 695888 Facsimile: 01903 695666
e-mail: info@eurotherm.co.uk
Website: <http://www.eurotherm.co.uk>

